

Permeability Plugging Apparatus Instruction Manual



Manual No. 204249, Revision E

Instrument No. 206845, 115V

Instrument No. 206846, 230V

PPA Instruction Manual

©2016 Fann Instrument Company

Houston, Texas, USA

All rights reserved. No part of this work covered by the copyright hereon may be reproduced or copied in any form or by any means (graphic, electronic, or mechanical) without first receiving the written permission of Fann Instrument Company, Houston, Texas, USA.

Printed in USA.

The information contained in this document includes concepts, methods, and apparatus which may be covered by U.S. Patents. Fann Instrument Company reserves the right to make improvements in design, construction, and appearance of our products without prior notice.

FANN[®] and the FANN logo are registered trademarks of Fann Instrument Company in the United States and/or other countries. All other trademarks mentioned in the operating instructions are the exclusive property of the respective manufacturers.

Contact FANN



Phone

TELEPHONE: 281-871-4482
TOLL FREE: 800-347-0450
FAX: 281-871-4358



Mail

Fann Instrument Company
P.O. Box 4350
Houston, Texas, 77210 USA



Location

Fann Instrument Company
14851 Milner Road, Gate 5
Houston, Texas, 77032, USA



Online

www.fann.com
fannmail@fann.com

Table of Contents

1 Introduction.....6
 1.1 Permeability Plugging Test6
 1.2 Document Conventions7
 2 Safety8
 2.1 Safe Pressurization.....8
 3 Features and Specifications.....12
 4 Installation14
 5 Filtration Test Procedure.....16
 5.1 Preheating the Heating Jacket.....16
 5.2 Preparing the Cell.....17
 5.3 Pressurizing the PPA Cell.....26
 5.4 Performing the API Filtration Test.....28
 5.5 Shutdown and Disassembly.....29
 6 Test Analysis32
 6.1 References.....32
 7 Maintenance33
 7.1 Cleaning33
 7.2 Cell Maintenance.....33
 7.3 Pressurization Systems35
 7.4 Regulator Troubleshooting.....36
 7.5 Regulator Repair38
 7.6 Hydraulic Pump and Regulator38
 7.7 Hydraulic Quick Disconnect.....39
 7.8 Heating Jacket.....40
 8 Accessories44
 9 Parts List.....45
 10 Warranty and Returns.....60
 10.1 Warranty.....60
 10.2 Returns.....60

List of Figures

Figure 3-1 Permeability Plugging Apparatus Assembly	13
Figure 4-1 PPA Set Up	15
Figure 4-2 Pump Assembly	15
Figure 5-1 Cell Assembly Drawing	18
Figure 5-2 Piston Position in PPA Cell	22
Figure 5-3 Final PPA Cell Arrangement.....	23
Figure 7-1 CO ₂ Regulator, Exploded View	37
Figure 7-2 Heating Jacket Assembly, Exploded View.....	40
Figure 9-1 PPA Assembly	46
Figure 9-2 Wiring Diagrams for Heating Wells.....	47
Figure 9-3 PPA Cell Assembly	48
Figure 9-4 Heating Jacket, 115V	50
Figure 9-5 Backpressure Receiver Assembly.....	52
Figure 9-6 CO ₂ Pressuring Unit.....	53
Figure 9-7 PPA Pump Assembly	54
Figure 9-8 Hydraulic Pump, Top & Side Views	56
Figure 9-9 Hydraulic Pump, End View.....	58
Figure 9-10 Pressure Regulator	59

List of Tables

Table 3-1 Permeability Plugging Apparatus Specifications	12
Table 5-1 Backpressure Settings at Various Test Temperatures	27
Table 8-1 Accessories	44
Table 8-2 Ceramic Filter Discs	44
Table 9-1 PPA Assembly, P/N 206845, 115V/800 Watts, Revision D	45
Table 9-2 PPA Assembly, P/N 206846, 230V/800 Watts, Revision C	45
Table 9-3 PPA Cell Assembly, 5000 psig, P/N 206850, Revision B	48
Table 9-4 Heating Jacket, P/N 209437, 115V	49
Table 9-5 Heating Jacket, P/N 101443622, 230 V	51
Table 9-6 Backpressure Receiver Assembly, P/N 209445, Rev C	52
Table 9-7 Carbon Dioxide Pressuring Unit, P/N 209471, Rev E	53
Table 9-8 PPA Pump Assembly, P/N 206869, Rev C	54
Table 9-9 Hydraulic Pump, P/N 205222	55
Table 9-10 Hydraulic Pump, End View, P/N 205222	57
Table 9-11 Pressure Regulator, P/N 204899	59

1 Introduction

The Permeability Plugging Apparatus (PPA) is a high pressure, high temperature instrument designed to simulate downhole static filtration. The PPA operates at temperatures and pressures that represent well conditions, and the filtration medium is positioned above the sample fluid.

The filter media is a ceramic disc. These discs closely simulate the structure of the formation, providing a more authentic representation of the filter cake that is actually being developed on the wall of the formation. Ceramic discs are available in several pore sizes. See Table 8-2.

1.1 Permeability Plugging Test

The permeability plugging test is useful in predicting a drilling fluid's ability to form a semipermeable filter cake that will seal off depleted underpressure intervals and help prevent differential sticking.

Pressure is applied from the bottom of the cell and filtrate is collected from the top. This arrangement prevents particles that settle during the static test from contributing to the buildup of filter cake. This is important because settling would not normally happen in a well.

Hydraulic pressure is transferred to the drilling fluid sample through a floating piston within the cell. Hydraulic oil and sample contamination is prevented through an O-ring seal on the piston.

The maximum test pressure is 5000 psi (34,474 kPa) and the maximum temperature is 500°F (260°C). The maximum pressure for the backpressure receiver is 750 psi (5171 kPa).

For temperatures greater than the boiling point of the sample fluid, the backpressure receiver must be pressurized to prevent vaporization of the filtrate. The standard backpressure receiver uses a carbon dioxide (CO₂) pressurizing source to provide the backpressure. A nitrogen pressure source and nitrogen manifold may be substituted for the carbon dioxide when desired. If an ion analysis of the filtrate will be completed, then nitrogen should be used for the backpressure.

1.2 Document Conventions

The following icons are used as necessary to distinguish elements of text.



NOTE. Notes emphasize additional information that may be useful to the reader.



CAUTION. Describes a situation or practice that requires operator awareness or action in order to avoid undesirable consequences.



MANDATORY ACTION. Gives directions that, if not observed, could result in loss of data or in damage to equipment.



WARNING! Describes an unsafe condition or practice that if not corrected, could result in personal injury or threat to health.



ELECTRICITY WARNING! Alerts the operator that there is risk of electric shock.



HOT SURFACE! Alerts the operator that there is a hot surface and that there is risk of getting burned if the surface is touched.

2 Safety

This section explains the safety measures for heating, pressurization, electrical operation, and handling of the PPA.

Safe laboratory practices and procedures should be observed while operating and maintaining the PPA.

Please review standard safety practices for handling high pressure, high temperature equipment and test cells.

2.1 Safe Pressurization

Follow these instructions for the hydraulic pressurization system and the backpressure receiver.

2.1.1 Hydraulic Pressurization System

Make sure that the hydraulic pressure has been released and that the pressure gauge reads zero **before**:

- Disconnecting the hose from the cell at quick connector
- Removing the cell from the heating chamber
- Moving the PPA
- Refilling the oil reservoir with hydraulic fluid
- Performing any maintenance

When refilling or repairing the hydraulic system, wipe spilled oil. Oil on the floor is a fall hazard. Spilled oil attracts dirt and can be a fire hazard.

When assembling the cell, make sure that the O-rings in the end caps are properly seated and the retainer ring is properly tightened.

2.1.2 Backpressure Receiver

For temperatures greater than the boiling point of the sample fluid, the backpressure receiver must be pressurized to prevent vaporization of the filtrate.

Gases

- Always use either nitrogen or carbon dioxide to pressurize the backpressure receiver. Never use compressed air, oxygen or other gases.
- Nitrogen must be supplied in an approved nitrogen gas cylinder or laboratory supply system. Nitrogen cylinders must be secured to meet safety standards.
- Carbon dioxide is usually supplied in small cartridges which contain about 900 psi (6206 kPa) pressure.



Do **NOT** allow carbon dioxide cartridges to be heated or exposed to fire. These cartridges can explode if overheated.

Pressure Regulators

- Maintain pressure regulators in good condition.
- Never use oil on pressure regulators.
- Leaking pressurization systems, hydraulic or pneumatic, should be repaired or replaced.
- Regularly inspect gauges, fittings, and hoses. Check for leaks.
- Periodically test the safety relief valve on the pressurization manifold to verify it will relieve if excessive pressure should occur. Never plug or bypass this safety valve.
- When pressurizing the backpressure assembly, always open the supply pressure first, and then adjust the regulator.
- Do not attempt to pressurize higher than the equipment is rated for or above the relief valve settings.
- When depressurizing, shut off the supply pressure, bleed the system of pressure, and then back out the regulator T-screw.

2.1.3 Safe Heating

Caution should be exercised by all personnel working with the PPA or working in the area where the PPA is in operation to avoid accidental injury caused by touching the heating jacket or cell assembly when they are hot. The heating chamber can operate at a temperature that will cause burns if touched. Safeguard the equipment after the test ends long enough for it to cool. It can still cause burns even after it has been turned off.

Removing the cell before it has cooled and placing it in water is very dangerous. This practice is not recommended because the user could be severely burned by the steam. Also, the user could be burned if the cell is touched or accidentally dropped.

Be careful when handling a hot cell. Wear thermally insulated gloves. The recommended procedure is to let the cell cool in the heating chamber before removing it.

A cell removal tool (P/N 209497) is available for handling the cell assembly and removing it from the heating chamber. Using the cell removal tool will reduce the risk of accidentally dropping the cell or being burned by a hot cell.

2.1.4 Safe Electrical Operation

Make sure the electrical source is fused and grounded.

Verify that the power cord is in good condition and has the proper ground connection.

Electrical problems in the wiring or heaters may not be obvious by looking at the equipment. If a fuse blows, circuit breakers trip, the heating time seems too long or the thermostat control does not respond, electrical repair may be required.

Always test the heating chamber for proper operation after repair or part replacement.



Always disconnect the power cable before performing any repair.

2.1.5 Safe Test Cell Maintenance



These instructions are for use only with a 5000 psi (34,473 kPa) working pressure cell. Do not pressurize cells above their stamped ratings.



Fann PPA cell assemblies do not use set screws. However, PPA cells made by other manufacturers may use set screws.

The PPA cell assembly is a pressure vessel. These safety precautions should be followed to assure safe operation:

- Cell material should be compatible with the test sample.
- Cell bodies that show signs of stress cracking, severe pitting, or have damaged set screw holes must not be used.
- Cell caps with pulled or deformed set screw seats must not be used.
- Damaged set screws must not be used. Do not substitute low strength steel or stainless steel set screws.
- Cells, cell caps, or retainer rings that have damaged threads must not be used.

The 5000 psi test cell features a 6150 psi (42,403 kPa) rupture disc in the bottom end cap and a 999 psi (6888 kPa) rupture disc in the floating piston. These devices will relieve the pressure to atmosphere if the pressure exceeds the limits

3 Features and Specifications

The Permeability Plugging Apparatus is a high temperature, high pressure instrument that has a maximum operating temperature of 500°F (260°C) and a maximum operating pressure of 5000 psi (34,473 kPa).

The standard 5000 psi PPA filter press cell, end cap, and retainer ring are made of Type 17-4 stainless steel and the floating piston is made of Type 303 stainless steel. Refer to Table 3-1 for the PPA specifications.

The PPA assembly consists of the following items:

- PPA Heating Jacket
- 5000 psi stainless steel PPA cell
- Backpressure Receiver
- Carbon Dioxide Pressurizing Assembly
- Carbon Dioxide Cartridges
- Hydraulic Hand Pump Assembly
- Dial Thermometer
- Graduated Cylinder

See Figure 3-1 for the PPA assembly.

Table 3-1 Permeability Plugging Apparatus Specifications

Category	Specification
Pressure Range	0 to 5000 psi (34,473 kPa)
Temperature Range	50°F to 500°F (10°C to 260°C)
Power Supply	115V/230V, 50/60 Hz, 800 watts
Dimensions (Width x Depth x Height)	8 x 25 x 12 inches 20 x 63.5 x 30.5 centimeters
Weight	66 lb (30 kg)



Figure 3-1 Permeability Plugging Apparatus Assembly

4 Installation

Figures 4-1 and 4-2 show the setup for the PPA assembly and pump assembly.

Place the PPA assembly in a location where the unit can operate with minimum disturbance and has suitable space and electrical power. The area immediately above the PPA heating jacket should be enough space for the backpressure assembly. The type of pressurizing system may also dictate installation specific requirements, such as having a large compressed gas cylinder secured nearby.

There should also be sufficient storage area nearby for commonly used tools, as well as consumables, such as ceramic filter discs and pressurizing cartridges.

Consideration should be given to the location where samples are prepared and the cells are cleaned following test completion.



Figure 4-1 PPA Set Up

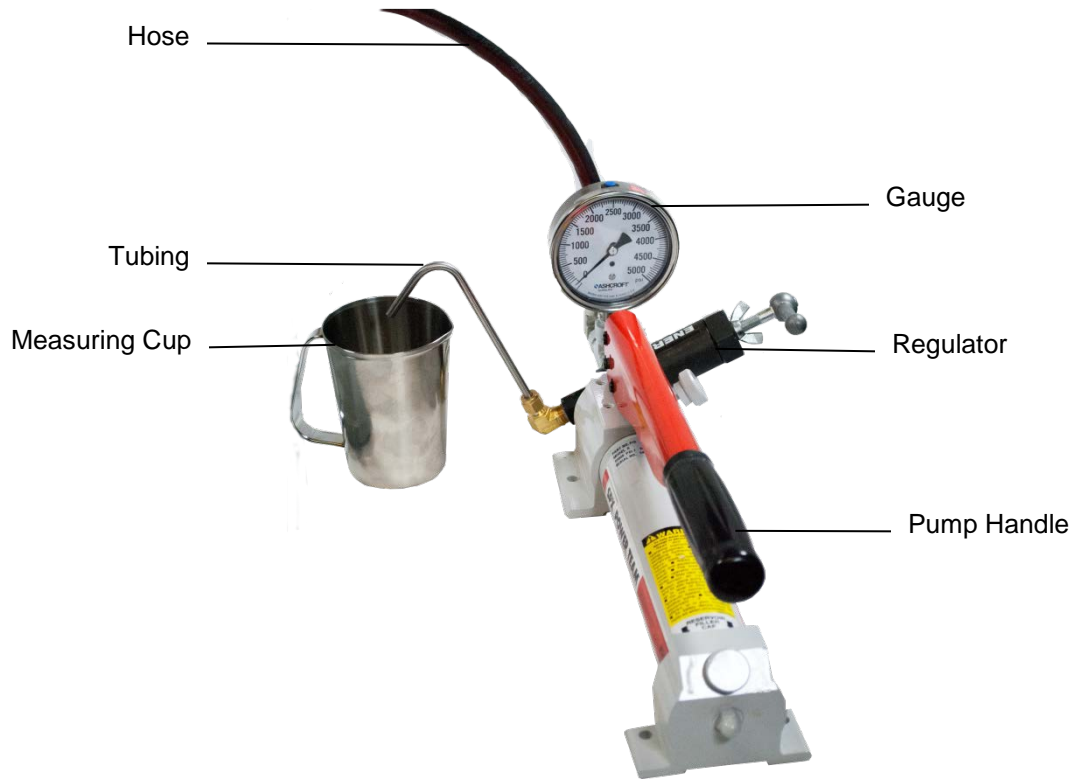

Figure 4-2 Pump Assembly

5 Filtration Test Procedure

Before starting the test procedure, you must remove the regulator assembly, backpressure receiver assembly, and the PPA cell from the heating jacket.

5.1 Preheating the Heating Jacket

1. Connect the power cable to the proper line voltage which is indicated on the nameplate.
2. Set the thermostat to 4 or 5.
3. Place the dial thermometer in the thermometer well of the heating jacket.
4. The pilot light will turn on when the heating jacket temperature has reached the thermostat setting.
5. Adjust the thermostat as necessary to obtain the desired test temperature.

5.2 Preparing the Cell



The PPA cell assembly is a pressure vessel. Follow the safety instructions listed in Section 2.



Cell material should be compatible with the test sample. The cell body, cell end caps, and retainer ring are made of Type 17-4 stainless steel. The floating piston is made of Type 303 stainless steel.



Cell bodies that have stress cracking or severe pitting, or damaged set screw holes must not be used.

Refer to these figures while performing the procedure:

- Figure 5-1, a drawing of the disassembled cell
- Figure 5-2, a drawing that shows the position of the floating piston and hydraulic fluid level in the PPA cell (cell is inverted)
- Figure 5-3, a drawing that shows how the PPA cell is arranged (cell is upright)

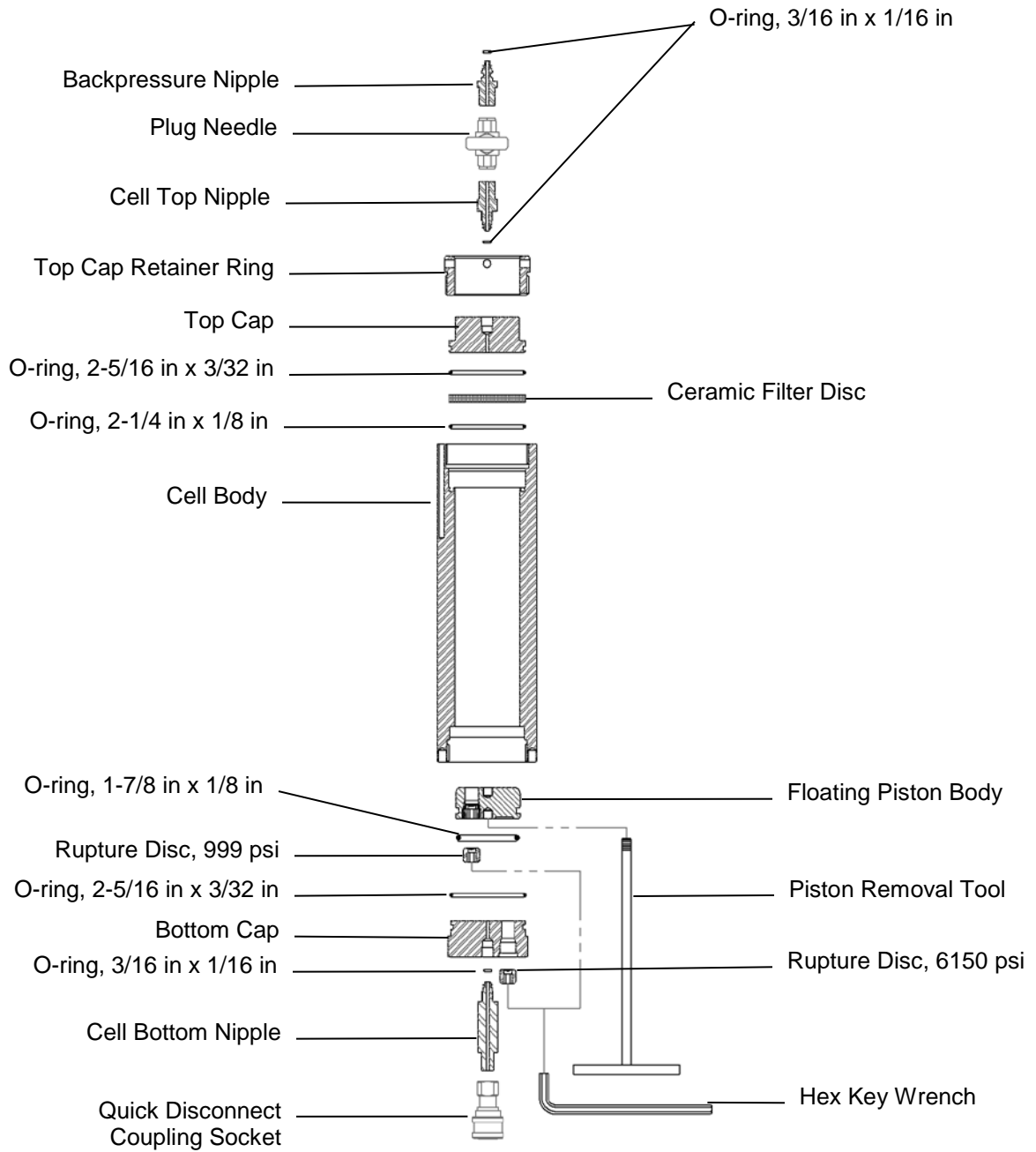

Figure 5-1 Cell Assembly Drawing

1. Soak the ceramic discs before running a filtration test. See notes below.



For water-based drilling fluids, the ceramic disc should be soaked for at least 5 minutes in fresh water or brine prior to use.



For oil-based drilling fluids, the ceramic disc should be soaked for 5 to 10 minutes in representative base oil prior to use.



Filter discs should never be re-used.

2. Unscrew the retainer ring, and then pull the top cap from the cell using the filtrate valve assembly as a handle. (The filtrate valve assembly consists of the backpressure nipple, plug needle, and cell top nipple.)



The retainer ring can be left on the top cap. If the O-rings are stuck, use the filtrate valve assembly to move the end cap back and forth.

3. Inspect all O-rings. Replace any damaged or brittle O-rings.



The O-ring supporting the ceramic disc must be replaced after each test.

4. Apply a thin coating of high temperature grease (P/N 204816 or equivalent) completely around all new O-rings installed in the cell assembly and floating piston.



If you have disassembled the PPA cell or if you are using a new PPA cell, then install the floating piston and bottom end cap. Next, you will need to fill the area above the piston with hydraulic fluid and remove air from the space between the floating piston and end cap. See Section 5.2.1 for instructions.

5. Connect the bottom nipple assembly to pump hose, and pump enough hydraulic oil to expel all air from the nipple. Disconnect the pump hose. Install and tighten the bottom nipple assembly into the bottom end cap.
6. Turn the cell upright on a suitable stand.
7. Install O-ring in the groove in the top of the cell.
8. Pour 275 ml of the sample fluid into the cell. Do not exceed this amount.
9. Reconnect the pump hose to the bottom nipple assembly. Close the pressure release valve on pump. See the pump assembly, Figure 4-2.
10. Operate the pump to lift the sample level to sit below the O-ring groove. Avoid spilling sample on the O-ring. Disconnect the pump.
11. Set a presoaked filter disc on top of the O-ring in the cell.
12. Open the filtrate valve and install the top end cap with filtrate valve assembly into the cell.
13. Lubricate the threads and the bottom end of the retainer ring with high temperature grease. Screw the retainer ring into the top of the cell. If necessary tighten by using the single pin end of the spanner wrench (P/N 206864) until the outer knurled flange of the retainer ring is against the top of the cell body. Further tightening is unnecessary and will make the cap more difficult to remove.
14. Make sure that the filtrate assembly is fully assembled and tightened into the top cap. Close the filtrate valve.
15. Place the oil measuring cup under the tubing, as shown in Figure 4-2, and operate the pump with the hose disconnected. Set the regulating valve to the test pressure (+/- 200 psi) by turning the T-handle (on the regulating valve) clockwise to increase the pressure or counterclockwise to decrease the pressure.



The pressure will increase to its maximum value before the relief valve opens after which the pressure will decrease. The maximum pressure during heating will be limited by the regulating valve.



Operating the hand pump with the adjustable regulating valve will produce oil droplets into the measuring cup when the pressure exceeds the valve setting. When pressure first exceeds the valve setting, it will decrease until the valve finally closes. This decrease will be approximately 200 psi less than the opening pressure. The opening pressure will be what the temperature at the heating jacket will produce on the system.



When the closed cell is placed in the hot heating jacket, the pressure in the cell will begin to rise rapidly due to thermal expansion of the sample and the hydraulic fluid. The pump must be connected quickly to release hydraulic oil and prevent overpressurization. During heating, the pressure in the cell will be limited by the regulating valve and bled into the measuring cup (Figure 4-4).



Wearing gloves and safety glasses is recommended for the following steps.

16. Make sure that the red knob is pulled out to move the cell support, and then install the cell into the heating jacket.
17. Lower the cell assembly and rotate it so that the locking pin in heating jacket bottom will seat into one of the holes in the cell.
18. Quickly connect the pump to the cell bottom.
19. Place the backpressure receiver onto the top of the filtrate valve assembly. Lock the backpressure receiver in place by installing the retaining pin.
20. Connect the drain hose from the drain valve into the graduated cylinder.

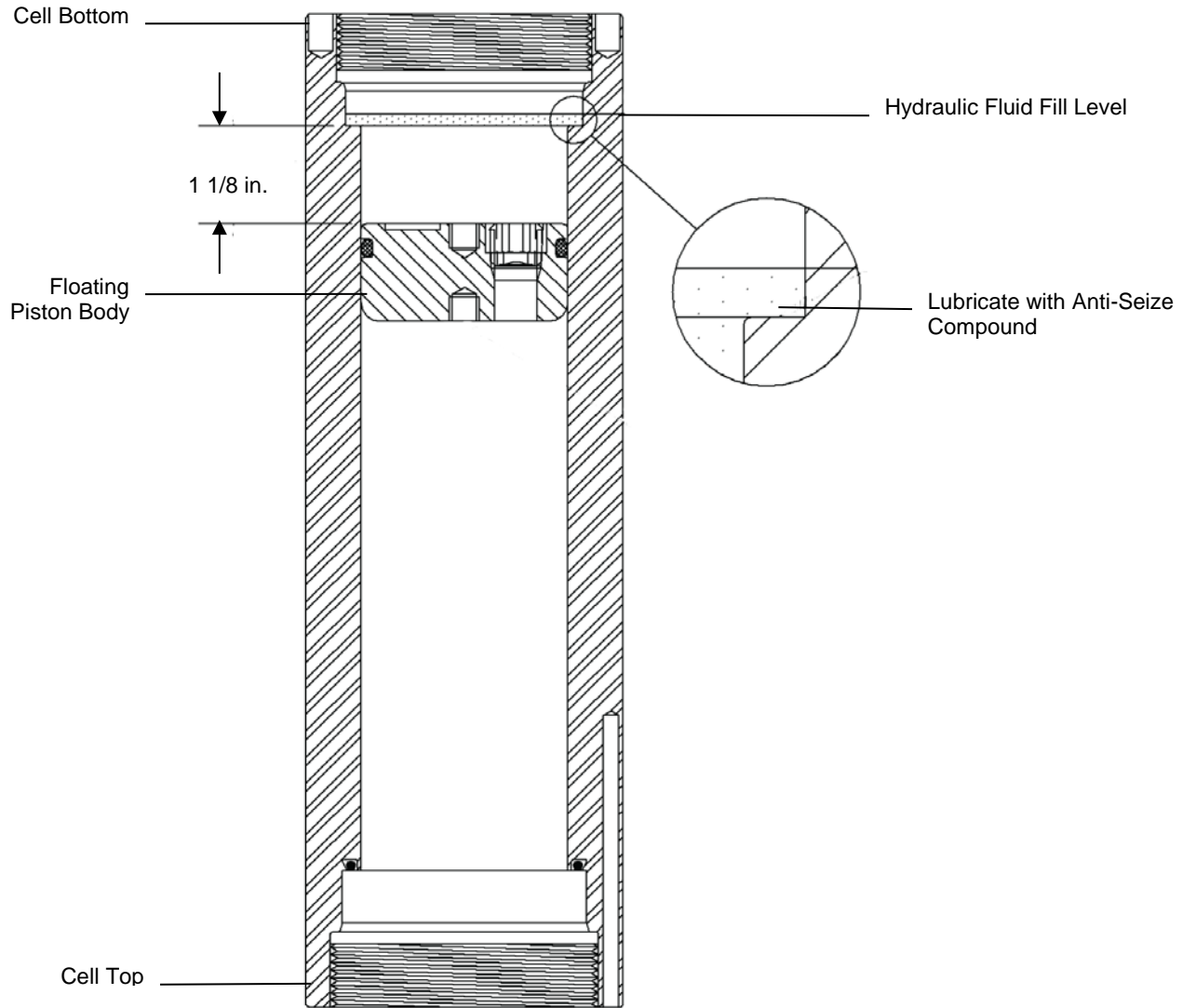

Figure 5-2 Piston Position in PPA Cell

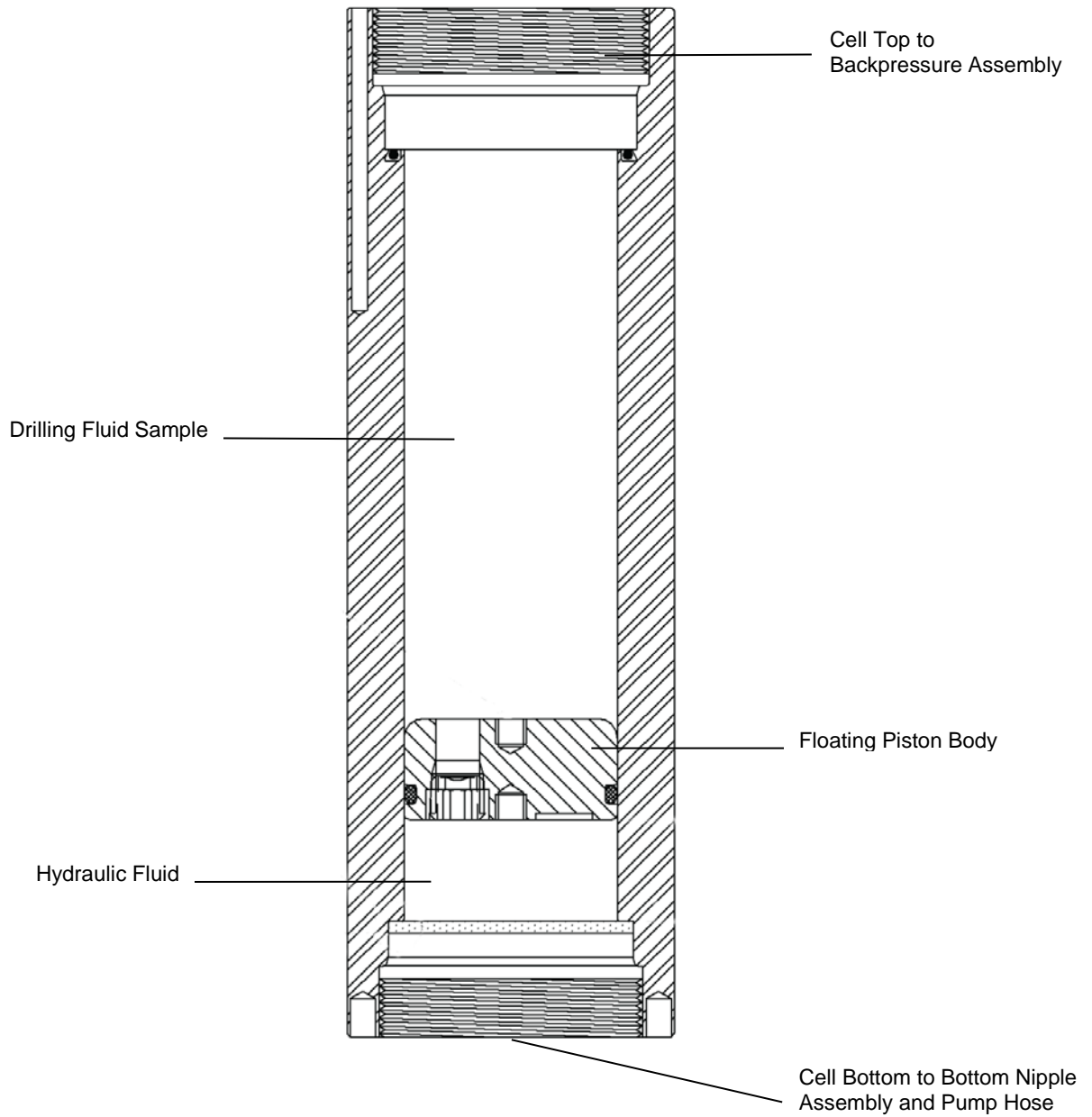

Figure 5-3 Final PPA Cell Arrangement

5.2.1 Removing Air from Hydraulic Side of the Cell



If you have disassembled the PPA cell or if you are using a new PPA cell, install the floating piston and bottom end cap. Next, you will need to fill the area above the piston with hydraulic fluid and remove air from the space between the floating piston and end cap as described here.

Refer to Figure 5-2.

1. If necessary, install the floating piston and bottom end cap. Follow these steps to remove air from the hydraulic side of the cell:
 - a. Screw the T-bar into the O-ring end of the floating piston.
 - b. With the cell upside down (Figure 5-2), install the piston into the cell bottom, curved end first.



The bottom of the cell is the end that has two locking pin holes.

- c. Position the piston 1-1/8 inch below the inner cell lip of the cell bottom, and remove the T-bar wrench.
2. Lubricate the end of the cell bore with high temperature grease.
3. Fill the area above the piston with hydraulic oil, covering the area that was lubricated with grease.
4. Lubricate the threads with high temperature grease. Then screw the bottom end cap into the cell. Gently tighten using the two pin end of spanner wrench (P/N 206864). Overtightening will not improve the seal, but will make the bottom end cap more difficult to remove.



Some hydraulic oil will flow from the threaded center hole in the bottom end cap. When hydraulic oil flows, it is a sign that air is not trapped in the hydraulic end of the cell.

5. Connect the bottom nipple assembly to the pump hose.
6. Pump enough hydraulic oil to expel all air from the nipple.
7. Disconnect the pump hose.
8. Install and tighten the bottom nipple assembly into the bottom end cap.

5.3 Pressurizing the PPA Cell



Filtration at temperatures above the sample's boiling point requires a backpressure receiver. The cell and the backpressure receiver should both be pressurized to the specified backpressure while the cell is heating. See Table 5-1.

1. Install the CO₂ pressure assembly onto the top of the backpressure receiver and lock it in place with retaining pin.
2. Make sure that the regulator T-screw is backed out (counterclockwise) to release diaphragm pressure. After the pressure has been released, the T-screw will turn more freely.
3. Remove the barrel from the pressure unit and insert one CO₂ cartridge into the barrel, blunt end first.
4. Screw the barrel onto the pressure unit, and then tighten the barrel to puncture the CO₂ cartridge. Do not adjust the regulator.
5. Make sure the pressure release valve on the CO₂ regulator assembly, the filtrate drain valve, and the filtrate valve are closed.
6. Apply the appropriate amount of backpressure for the desired test temperature. Refer to Table 5-1.
7. Turn the T-screw on the pressure regulator clockwise until the desired pressure is shown on the gauge.
8. Operate the pump to pressurize the cell approximately equal to the value of the backpressure setting, but less than the regulating valve pressure setting.
9. Allow the cell to heat until the cell is at the test temperature. The regulating valve should maintain cell pressure at or below the pressure setting during heat up. The thermometer may be moved from the heating jacket to the cell to accurately determine when the cell temperature has reached the test temperature.
10. Maintain the desired test temperature in the cell until the pressure in the cell stops rising. When the pressure is steady, fluid will not drip into the cup, indicating that the sample and hydraulic fluid are at a uniform temperature. This may take as long as an hour.

11. When the test temperature is reached, the regulating valve can be adjusted slightly. Use the hydraulic pump and turn the regulator handle slightly to adjust the cell to the test pressure. The test is now ready to be started.

Table 5-1 Backpressure Settings at Various Test Temperatures

Test Temperature		Minimum Backpressure	
°F	°C	psi	kPa
200	< 95	0	0
200-300	95-150	100	690
301-350	151-175	150	1050
351-375	178-190	200	1400
376-400	191-205	250	1725
401-425	206-218	350	2420
426-450	219-232	450	3100
451-475	233-246	550	3800
476-500	247-260	700	4850

Source: API RP 13B-1



Use 275 ml of sample to allow for expansion during heating. Do not exceed this amount.



The differential filtration pressure is the test pressure less the backpressure.

5.4 Performing the API Filtration Test

1. Verify that the backpressure shown on the pressure regulator gauge meets the minimum backpressure from Table 5-1. The minimum backpressure is a conservative estimate. The key is to maintain pressure in the backpressure receiver throughout the entire test.
2. Set a timer for 30 minutes or other desired filtration test time. Start the timer.
3. Open the filtrate valve by turning it counterclockwise $\frac{1}{2}$ turn to start the filtration. The cell pressure, indicated on the pump gauge, will drop initially. Operate the pump to maintain the desired test pressure.



When the filtrate valve is open, always monitor the readings on the backpressure receiver pressure gauge. If the pressure increases by a factor of two, then the receiver is over one-half full, indicating a failed test. In this case, the filtrate valve should be shut off and the test discontinued.

4. One minute after valve is opened and the desired pressure is applied, open the drain valve on the backpressure receiver and collect the filtrate.
5. Continue to collect the liquid until the reservoir blows dry.
6. Shut the drain valve. The filtrate volume should be recorded as the initial spurt loss.
7. The cell pressure will probably decrease as the test continues due to volume loss through filtration. Apply additional pressure to the cell in order to maintain a constant test pressure. Use the hand pump to obtain a pressure reading that is slightly less than the relief valve pressure.
8. After obtaining an initial spurt loss at one minute, repeat the process for 7.5 minutes for second spurt loss measurement. Maintain the desired test pressure on the cell and on the backpressure receiver for the duration of the test.
9. After 30 minutes, close the filtrate valve and drain all the filtrate from the backpressure receiver into the graduated cylinder.
10. Record the total volume of filtrate in the graduate cylinder as total filtrate.

5.5 Shutdown and Disassembly

1. Disconnect the heating jacket from the power source.



Do **NOT** continue this procedure until the sample temperature in the cell is less than 200°F (93°C).

2. Wait until the cell has cooled to 200°F (93°C) or lower.
3. Release the backpressure by turning the adjusting T-screw on the backpressure regulator counterclockwise.
4. Open the bleed valve on the CO₂ pressurizing unit to depressurize the backpressure receiver.
5. Remove locking pin and remove the CO₂ pressure assembly from the top nipple adapter.
6. Remove locking pin and remove the backpressure receiver.
7. Open the valve on the hydraulic pump to release the cell pressure.
8. Then disconnect the hydraulic quick disconnect.
9. Open the filtrate valve. This will bleed any pressure remaining between the cell filter and the backpressure receiver.



Make sure that all pressure is released from the cell. If the cell has pressure, then make sure that it is cooled to room temperature before relieving the pressure.



To make sure that pressure is totally released, follow these instructions: 1) Remove the quick-connect assembly from the bottom end cap; 2) Insert a wire or drill bit through the end cap to locate the floating piston. If the floating piston is not on the bottom, then there is no pressure; 3) If the floating piston is on the bottom, pressure could be present in the cell. Reconnect the hydraulic pump and pump several strokes to move the floating piston. If the cell contains pressure, it will be obvious because force will be required to move the floating piston.



If the cell contains pressure, first make sure that the cell is cooled to room temperature. Then, remove the filtrate valve assembly and insert a small drill bit or wire into the cell cap to remove the obstruction. The drill or wire will stop when it contacts the filter disc. Wear gloves and point the opening away from you when inserting the drill bit or wire.

10. Remove or raise the cell assembly. The cell can be supported on the cell support (red knob pushed in) or lifted from the heating well. To raise the cell assembly in the heating jacket use either the filtrate valve assembly or the optional cell handling tool (P/N 209497). Attach the cell handling tool to the backpressure inlet nipple just above the filtrate valve where the backpressure receiver is normally attached. Secure using the valve stem locking pin.
11. After the cell cools to room temperature, open the top (filter end) of the cell. Fit the single pin end of the spanner wrench into one of the holes in retainer ring, and unscrew the retainer ring. (This is a right hand thread.) A tap on the wrench may be required to move it. If the cell is difficult to open, maybe the parts are insufficiently lubricated, over-tightened, or dirty. If necessary, use a suitable holding tool, such as a soft jaw vice, chain wrench, or strap wrench around the cell near the filter end to prevent the cell from rotating. A strap wrench (P/N 206557) is available.
12. Reposition the cell if required so that the filter end is up.
13. Then remove the top cap. If the cap is stuck, use the filtrate valve assembly to pull the cap from the cell.
14. Remove the filter disc. Use a small knife, small screw driver, or similar thin blade to pry the edge of the disc. Then remove the disc and filter cake. If required, wash the filter cake with fresh water, or a suitable solvent (for oil-

based sample). Then measure and record its thickness and remarks concerning its composition.

15. Empty the cell. Wash the inside of the cell with fresh water, or a suitable solvent (for oil-based sample). Removing the floating piston and the bottom end cap is not necessary unless the last test was performed at 425°F (218°C) or higher.
16. If testing was conducted at temperatures above 425°F (218°C), the O-rings on the bottom end cap and the floating piston body must be replaced.
 - a. Remove the bottom end cap.
 - b. Position the cell as described in steps 10 and 11, except that the cell is held near the bottom end and the two pin end of the spanner wrench is used.
 - c. Remove the floating piston. Screw the T-bar wrench into the floating piston and push or pull to slide the piston from either end of the cell.



The floating piston can be removed through the top end without removal of the bottom end cap.

- c. Remove any hardened or abraded O-rings on the piston and cap.
- d. Clean the parts for re-use. Take care not to damage the rupture discs in the floating piston and the bottom end cap.

6 Test Analysis

The fundamental filtration measurements include the filtrate volume and filter cake thickness.

The filtrate volume is calculated as follows:

Total Fluid Loss = Spurt Loss (ml) + [2 x 30 minute fluid recovery (ml)]

6.1 References

- API Recommended Practice for Field Testing Water Based Drilling Fluids, API RP 13B-1/ISO 10414-1
- API Recommended Practice for Field Testing Oil Based Drilling Fluids, API RP 13B-2

7 Maintenance

Troubleshooting and regular maintenance procedures are described in this section. If more extensive maintenance or service of the instrument is required, please contact Fann Instrument Company.

7.1 Cleaning

Standard laboratory procedures apply when cleaning the PPA and backpressure receiver. After each test, the cell top end and the backpressure receiver should be disassembled and thoroughly cleaned and dried of all sample and other contaminants, with particular attention to O-rings and O-ring grooves.

Wipe spilled sample or other debris from the heating jacket and stand. Some sample materials may damage the finish of these parts if allowed to remain on them for a long period of time.

7.2 Cell Maintenance

Refer to Figure 5-1.

7.2.1 O-rings

Inspect all O-rings for cuts or nicks while cleaning them. Check for hardening or brittleness. If the O-rings have been exposed to temperatures above 425°F (218°C), replace them.

Replace all damaged O-rings, including those on the bottom end cap and floating piston.

Lubricate all O-rings before installing them. For most applications, high temperature grease (thin coating) is sufficient. However, since some O-rings contact the sample, the lubricant must be compatible with the sample and must be applied sparingly.

The O-rings furnished with the instrument are suitable for temperatures up to 325°F (163°C). Special O-rings are available for testing up to 500°F (260°C). These special O-rings (P/N 204629) are for one-time use only.

7.2.2 Cell Top Closure

The cell top closure consists of the top cap, top cap retainer and one O-ring. The O-ring groove and the cylindrical outer surface of the top cap must be kept clean and in good condition. The thread for the nipple should be kept in good condition and lubricated when assembled.

The retainer ring has an external thread which engages a thread in the top of the cell body. Both threads must be kept clean and lubricated when assembled. Use high temperature grease (P/N 204816 or equivalent).

7.2.3 Cell Bottom Closure

The bottom end cap is one piece and has an external thread that engages an internal thread in the bottom of the cell body. The cap has a nominal 6150 psi (42,400 kPa) rupture disc built into it to prevent accidental overpressure. Both threads must be kept clean, free of burrs, and lubricated when assembled. Use high temperature grease (P/N 204816 or equivalent).

When cleaning, be careful not to damage the rupture disc. The rupture disc, if it should rupture, can be removed by unscrewing it from the bottom end cap using a ¼ inch hex wrench. Replace the rupture disc (P/N 206161). Use high temperature sealant on the threads. Do not damage the disc with the end of the hex wrench.

7.2.4 Floating Piston

The floating piston separates the hydraulic oil from the test fluid. It seals the inside of the test cell using one O-ring. It is round edged on the sample side and offset on the oil side. Each side has a blind hole to accept the T-wrench. The floating piston includes a nominal 999 psi (6888 kPa) rupture disc to limit the differential pressure between the cell hydraulic pressure and the backpressure receiver pressure. This rupture disc prevents cell overpressure if the floating piston sticks or bottoms out at the end of the cell. Do not damage the rupture disc when cleaning the floating piston.

The O-ring groove and the cylindrical outer surface of the piston must be kept clean and free of dings and burrs. Lubricate the O-ring whenever it is replaced with high temperature grease.

If the rupture disc should rupture, use a 1/4-in. hex wrench to remove it. Replace the rupture disc. Use high temperature sealant on the threads. Do not damage the disc with the end of the hex wrench.

7.2.5 Filtrate Valve

This is a multi-turn needle valve with a metal seat and high-temperature packing.

Wash the valve thoroughly to remove sample or other debris and dry.

Stem leaks can often be stopped by tightening the packing gland. If the valve does not close tightly, replace it. To check for leaks, remove the backpressure receiver (with the valve closed) and put soap solution on nipple end while operating at highest intended temperature and pressure. Bubbles indicate a leak.

7.2.6 Cell Corrosion



Corrosion, pitting, or stress cracking may cause the cells to fail.



The floating piston is composed of Type 303 stainless steel. The cell body, cell end caps, and retainer ring are composed of Type 17-4 stainless steel.

Stainless steel cells exposed to drilling fluid fluids under high-temperature and high-pressure conditions tend to experience corrosion.

Wash and inspect the cell for corrosion after each use. Use 320 grit (or finer) sandpaper, wet or dry, to remove light corrosion. Corrosion pitting may be removed by sandblasting the corroded area.

7.3 Pressurization Systems

Safe operation of pressurized equipment requires properly maintaining the pressurizing systems. Follow these procedures for the safe use of pressure regulators:

- Never expose a regulator to inlet pressure greater than its rated inlet pressure (shown on the regulator).
- Never use the regulator for gases other than those for which it is intended.
- All connections to the regulator must be clean. Remove oil, grease, or other contaminants from external surfaces and metal connecting parts.
- Never pressurize a regulator that has loose or damaged parts, or is in questionable condition.

- Never loosen or tighten a connection or part until the gas pressure has been relieved. Under pressure, gas can dangerously propel a loose part.
- Periodically, check the regulator and all connections for leaks after installation or after any service in which parts or connections were disconnected and reconnected. Add soapy water to a wash bottle and squirt the soapy water around these fittings. Bubbles indicate a leak.

7.4 Regulator Troubleshooting

The pressure regulator uses CO₂ to pressurize the backpressure receiver. See Figure 7-1.

The primary causes of regulator problems are

- Leakage around fittings
- Faulty pin seat
- Dirt or sample contamination in the regulator

Common symptoms of a faulty regulator are as follows:

- Gas leaks at the regulator outlet when the adjusting screw is completely released.
- Gas leaks from the spring case (the adjusting screw end of the regulator).
- Gas leaks from the relief valve.
- Gas leaks from any point.
- The working pressure steadily increases above the set pressure when there is no flow through the system (i.e., closed downstream valves and adjusting screw).
- The working pressure excessively drops when the regulator flow is open.

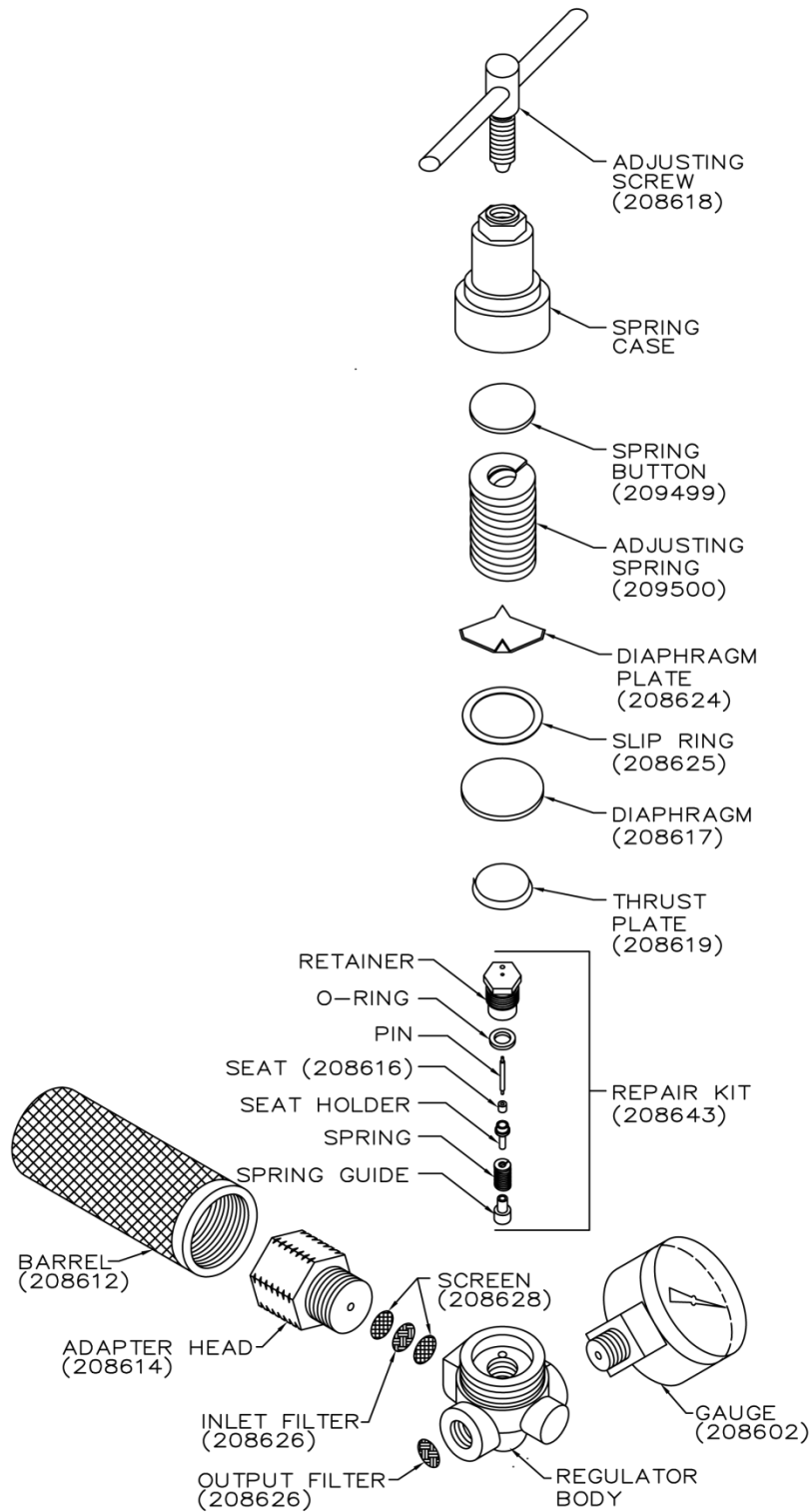

Figure 7-1 CO₂ Regulator, Exploded View

7.5 Regulator Repair

If the regulator is defective, disassemble, clean, and repair it. Refer to Figure 7-1 for order of disassembly and assembly.

Observe these guidelines when repairing a regulator:

- Thoroughly clean all parts. Make sure that the small orifices are open.
- Make sure that all non-metal parts, diaphragm, gaskets, O-rings and other parts, are not brittle, cracked, or deformed.
- Do not use oil on the internal parts of the regulator.
- Use pipe thread sealant on all pipe threaded fittings as they are assembled.
- Always pressure tests a regulator that has been recently repaired. Use the list of symptoms as a checklist.

7.6 Hydraulic Pump and Regulator

See Figures 9-8 and 9-9.

The PPA cell is pressurized with a hand-operated hydraulic pump (included) or an electric pump (optional). Maintaining clean hydraulic oil is essential. Hydraulic oil that will not break down at high temperatures is provided (P/N 207805).



A high-temperature hydraulic oil is provided. Do **NOT** use regular hydraulic oil at test temperatures above 250°F (121°C). If the oil leaks onto the hot heating jacket, a fire could occur.

If a pump leaks, it must be repaired. Disassemble the pump and replace the seals.

When a pump malfunctions, check the pump pistons or the control valve.

Fann Instrument Company offers a pump repair kit (P/N 205223) for this hand pump.

7.6.1 Pump Reservoir

Follow these instructions for draining and flushing the reservoir.

1. Remove the filler cap.
2. Drain the hydraulic fluid through the filler hole.
3. Remove the nut from the tie rod.
4. Separate the reservoir from the pump body.
5. Clean the reservoir and filter.



To prevent breaking the filter, do not remove it from the pump assembly. Clean the filter as well as possible with it installed.

6. Reassemble and fill the reservoir with hydraulic fluid. Attach the filler cap.
7. Next, clean the exterior of the pump.
8. Drain and clean the other hydraulic system components, such as the hose and cylinders before reconnecting them to the pump. Clean parts help prevent contaminated fluid from entering the pump.

7.6.2 Pump Pressure Regulator

This pressure regulator does not require maintenance. However, regularly cleaning the entire hydraulic system is recommended.

7.7 Hydraulic Quick Disconnect

The hydraulic quick disconnect prevents the loss of hydraulic oil from either direction when it is disconnected. Repair is not recommended. If they leak or fail, replace them.

7.8 Heating Jacket

Refer to Figure 7-2.

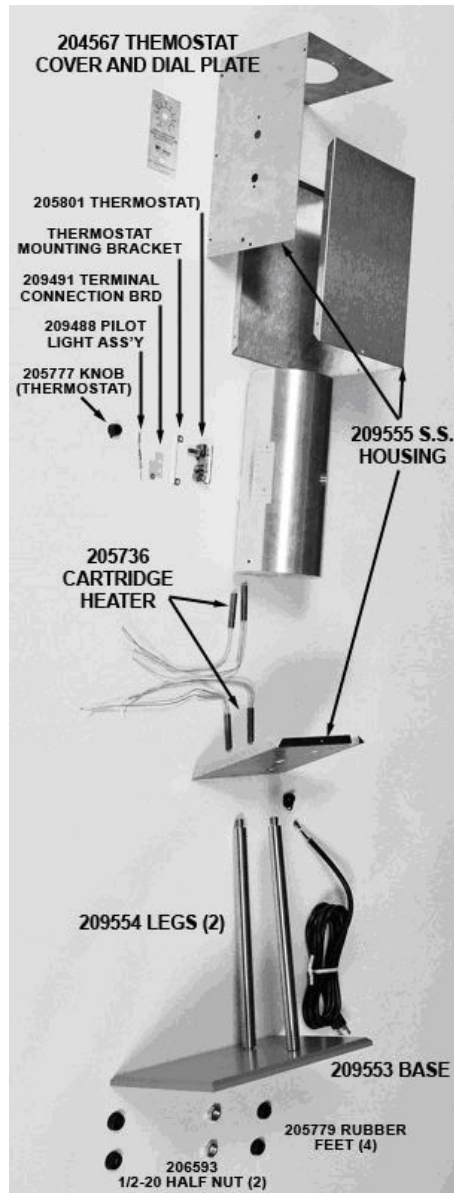

Figure 7-2 Heating Jacket Assembly, Exploded View

7.8.1 Disassembly

The stand and heating jacket assembly contains the thermostat, cartridge heaters, power cord, and insulated cover. When troubleshooting, look for burned or broken wiring, a failed thermostat, or burned out heaters.

Follow these instructions to disassemble the heating jacket.

1. Loosen the set screw and remove the thermostat knob.
2. Hold the cell support from inside the well and unscrew the red knob. Then remove the support rod from inside the well.
3. Lay the heating jacket and stand on its side. Remove the two ½-in thin nuts (P/N 206593) from the bottom of the base, and then remove the base (P/N 209553).
4. Unscrew the two legs (P/N 209554) from the heating jacket,
5. Remove six screws on the front and five screws on top. Then remove the front and top sheet metal.
6. Remove the insulation between the case (P/N 209446) and heating jacket. Then, slide the heating jacket (P/N 209438) out.
7. Remove one 6-32 x ¼ inch screw from the thermostat terminal connection board. Next, remove one wire from each heater and the power wire.
8. Remove the two terminal nuts and washers from the thermostat. Then remove the pilot light assembly, the power wire, the second heater wire from each heater, and the terminal board.
9. Remove two 6-32 x ¼ inch screws holding the thermostat. Then remove the thermostat.
10. Determine the condition of the four heaters as follows:
 - a. Using an ohmmeter, test the heaters individually. An open circuit between the leads indicates a faulty heater. A shorted heater will show continuity (no resistance) between the leads. A good heater will show approximately 60 to 70 ohms resistance.
 - b. Also, test each lead to the heater sheath or the heating jacket for ground. If the meter shows other than open, the heater is defective.



A defective heater presents a shock hazard.

11. If the heaters need to be replaced, first you may have to soak them in penetrating oil to loosen them. Push the two bottom heaters from the bottom of the heating jacket. Then pull the two top heaters by their leads past the wiring groove and out the bottom of the heating jacket.

7.8.2 Repair

Refer to Figure 9-2 which shows the wiring diagrams for the heaters.

1. After disassembling the heating jacket, inspect all components and replace burned or broken wires.
2. Check the condition of the thermostat. Connect an ohmmeter or continuity tester across the two set screw terminals. Notice if connection is made, and then broken after rotating the stem. If rotating the stem does not change the ohmmeter reading or the continuity tester indicator, replace the thermostat.

7.8.3 Reassembly

Reassemble the heating jacket in the reverse order of disassembly, considering the following instructions:

1. When installing new heaters, assemble the top heaters (two) from the bottom with the leads down. After the heaters are in place, pull the leads into the wiring groove.
2. Install the bottom heaters (two) with leads in first. Pull the leads into the wiring grooves as the heater is placed into the heating jacket.
3. The leads should be cut in order to fit neatly into the wiring groove and around the thermostat.
4. New high temperature wire lugs must be crimped onto the heater lead wires after fitting them to the proper length.
5. When reinstalling the pilot light assembly, make sure the bulb is directly behind the hole in the thermostat cover.
6. To properly align the pilot light assembly, it may be necessary to temporarily put the heating jacket in its cover. Then put the front/top sheet metal in place to determine the position of the pilot light hole.

7. Make sure that all screws and nuts around the thermostat are tight and that all wires are properly routed before installing the heating jacket into its case.
8. Reinstall the insulation between the heating jacket and the case. Replace insulation that is deteriorated or burned.
9. Make sure that the electrical insulating paper inside the front metal cover is in good condition. Use adhesive to mend torn electrical insulating paper or to attach new paper.
10. If the thermostat was replaced, make sure that the thermostat stop is properly set. The stop resembles a washer with a tang. The stop fits over the grooved stem of the thermostat. At room temperature and position 1 (the maximum counterclockwise position), the pilot light will come on. As the heating jacket heats, the thermostat should discontinue heating. At position 10 (the maximum clockwise position), the temperature is approximately 500°F (260°C). If the thermostat stop requires resetting, remove it from the stem of the thermostat, and rotate one or two grooves. Then, reinstall and retest the thermostat.
11. Install the legs and base.
12. Install the cell support and red knob.
13. Install the thermostat knob.

8 Accessories

Table 8-1 Accessories

Part No.	Description
205223	REPAIR KIT FOR HYDRAULIC PUMP, P/N 205222
206557	STRAP WRENCH, NO. 5
209497	CELL HANDLING TOOL
209547	NITROGEN MANIFOLD

Table 8-2 Ceramic Filter Discs

Part No.	API Designation	New Hg Data	Old Air Data Previous Designation
210536	10	10 μ	3 μ
210537	12	12 μ	5 μ
210538	20	20 μ	10 μ
210539	40	40 μ	20 μ
210540	50	50 μ	35 μ
210541	55	55 μ	60 μ
210542	120	120 μ	90 μ
210543	NONE	--	150 μ
210544	NONE	--	190 μ



The mean pore throat diameter of the ceramic filter disc is measured in microns (μ).



Ceramic filter discs are supplied in boxes of 10 cores. Each disc has the same porosity. The disc is 1/4 in. thick x 2-1/2 in. diameter.

9 Parts List

Table 9-1 PPA Assembly, P/N 206845, 115V/800 Watts

Item No.	Part No.	Quantity	Description
0001	209471	1	CO ₂ PRESSURING UNIT
0002	209445	1	BACKPRESSURE RECEIVER ASSEMBLY 100ml
0003	206850	1	CELL ASSEMBLY 5,000 PSIG 1/4in. DISC
0004	209437	1	HEATING JACKET
0005	206869	1	PUMP ASSEMBLY
0006	206039	1	DIAL THERMOMETER
0009	206870	1	BRACKET ASSEMBLY FOR GRADUATED CYLINDER
0010	205622	2	TYGON [®] TUBING 3/16 X 1/16
0011	205868	1	GRADUATED CYLINDER, GLASS 25ml TC
0012	210538	1	FILTER DISC API DESIGNATION 20,CERAMIC 10/BOX
0013	205869	1	GRADUATED CYLINDER, GLASS 10ml TC
0016	208608	1	CO ₂ CARTRIDGES 10/BOX

Table 9-2 PPA Assembly, P/N 206846, 230V/800 Watts

Item No.	Part No.	Quantity	Description
0001	208865	1	CABLE POWER 230V 18 AWG
0002	206845	1	PERMEABILITY PLUGGING APPARATUS

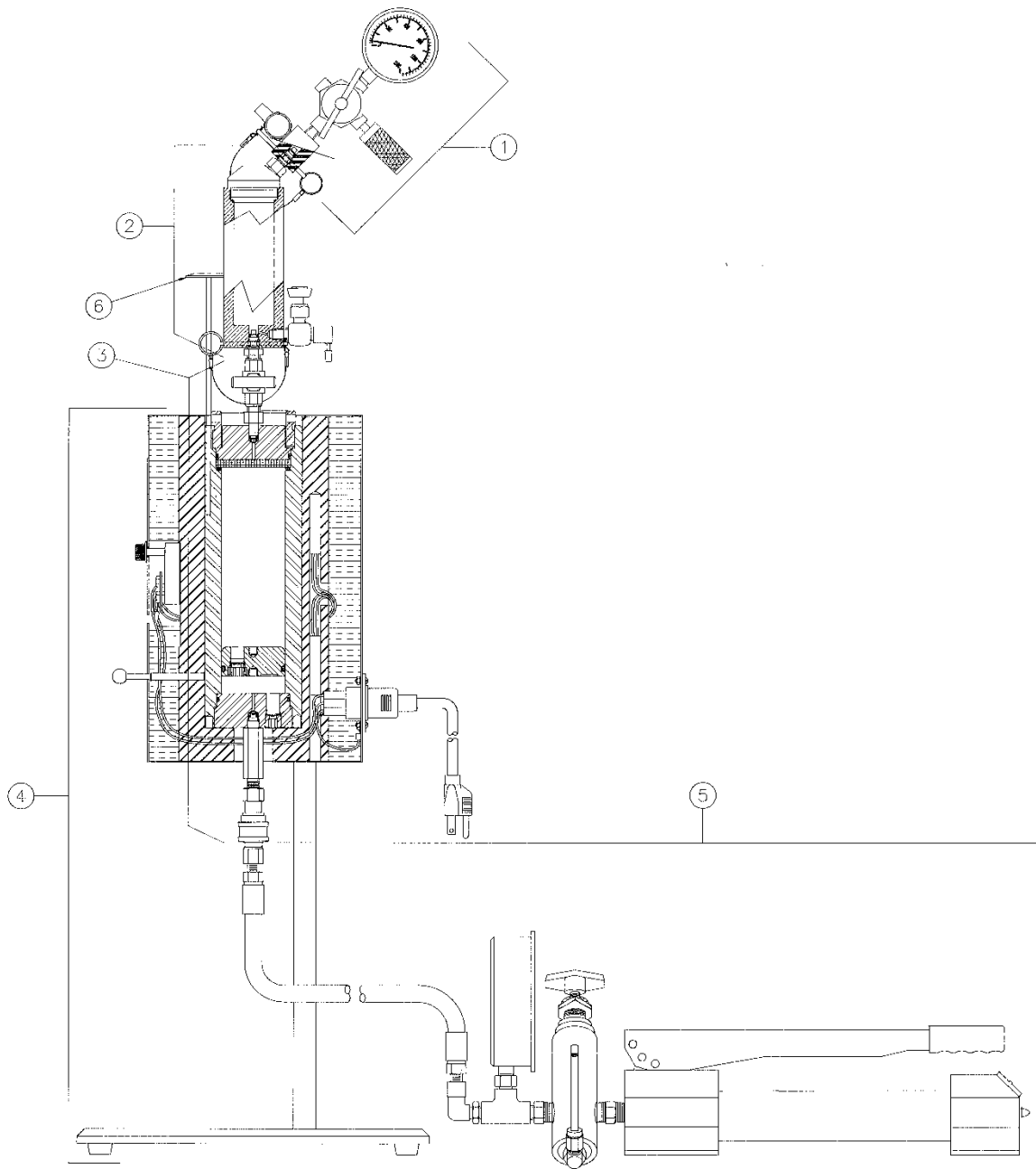
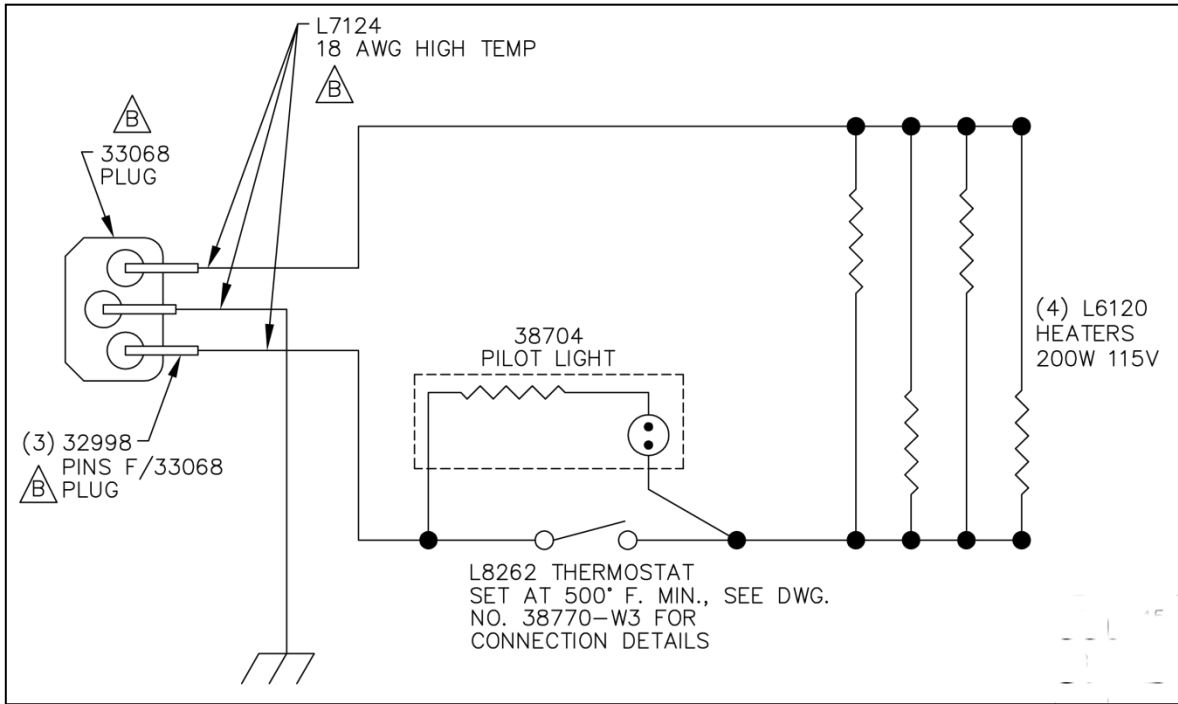
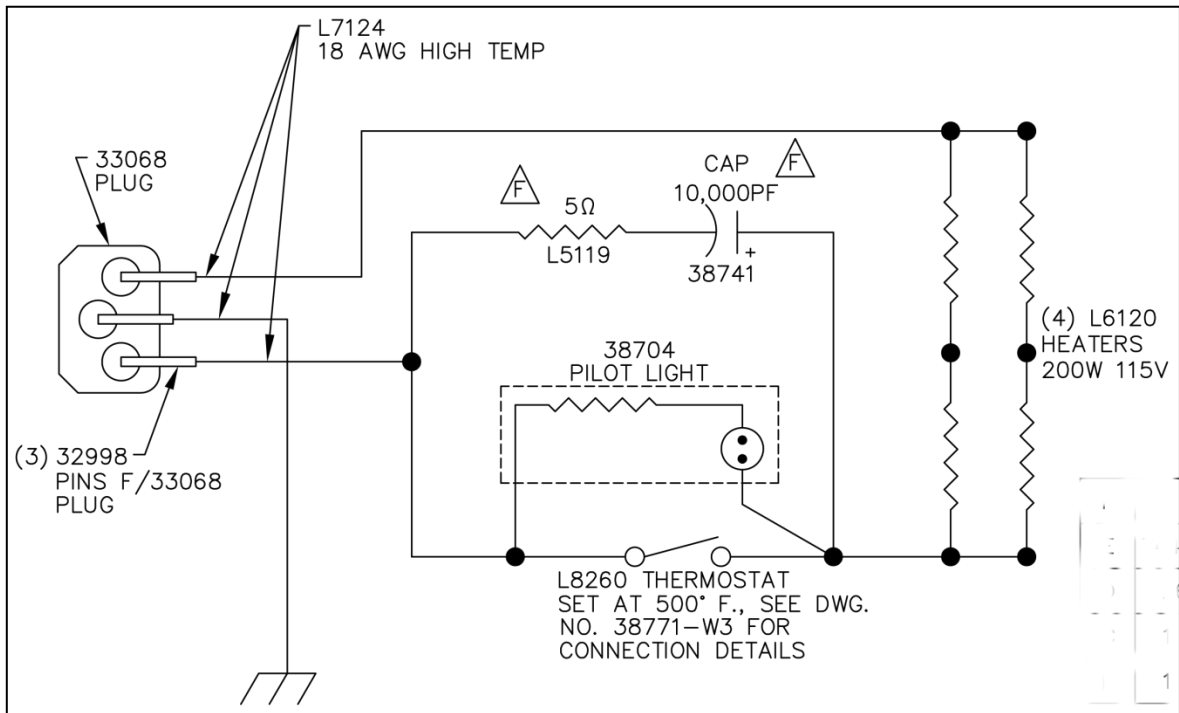

Figure 9-1 PPA Assembly



Wiring for 115V



Wiring for 230V

Figure 9-2 Wiring Diagrams for Heating Wells

Table 9-3 PPA Cell Assembly, 5000 psig, P/N 206850

Item No.	Part No.	Quantity	Description
0001	206853	1	RING RETAINER
0002	206854	1	TOP END CAP
0003	204627	10	O-RING 2-1/4 X 3/32
0005	206852	1	CELL BODY
0006	206863	1	FLOATING PISTON
0008	206161	1	RUPTURE DISC, 5500 PSIG NOM. (6150 PSI BURST @500°F) 1/4-in. MNPT
0010	206855	1	BOTTOM END CAP
0011	206864	1	SPANNER WRENCH
0012	209439	1	CELL TOP NIPPLE
0013	206848	1	CELL BOTTOM NIPPLE
0014	209442	1	BACKPRESSURE NIPPLE 1/4 NPT
0015	209444	1	PISTON REMOVAL TOOL
0016	204094	1	QUICK-DISCONNECT COUPLING SOCKET
0017	206156	1	NEEDLE VALVE 1/4-in. FNPT
0018	205649	9	O-RING 3/16 X 1/16
0019	205662	10	O-RING 2-1/4 X 1/8
0020	204249	1	INSTRUCTION MANUAL
0040	204629	10	O-RING 2-1/4 X 1/8
0050	204631	6	O-RING 1-7/8 in x 1/8 in
0060	204816	1	HIGH TEMP GREASE, 3 OZ.
0070	210435	1	ANTI-SIEZE HIGH TEMP LUBRICANT 1 OZ.

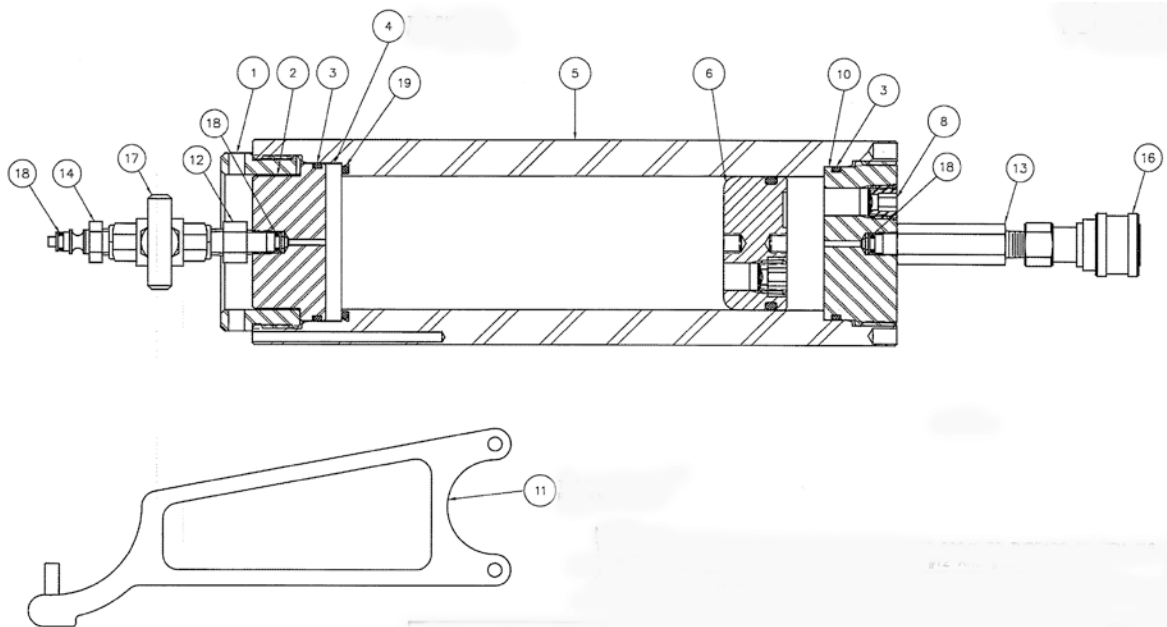

Figure 9-3 PPA Cell Assembly

Table 9-4 Heating Jacket, P/N 209437, 115V

Item No.	Part No.	Quantity	Description
0001	205801	1	THERMOSTAT 50-600°F
0002	209491	1	THERMOSTAT MOUNT PLATE
0003	208452	1	CABLE POWER 115V 18 AWG
0004	209488	1	NEON LAMP & CUP-HEATER
0005	208438	1	PLUG INTL ELECT CODE TYPE
0006	203392	3	6-32 X 1/4 RHMS STAINLESS STEEL
0007	208658	2	WASHER FLAT 6 STAINLESS STEEL
0008	204290	6	FIBERGLASS SLEEVING
0009	204293	10	RING TERMINAL NO. 6 SCREW 16-14AWG
0010	209438	1	HEATING WELL
0011	209446	1	HEATING JACKET COVER
0012	209447	1	CELL SUPPORT
0013	204565	1	TEMPERATURE CONTROL TAG
0014	209553	1	BASE
0015	209554	2	LEG
0016	210459	24	BULK INSULATION
0017	206593	2	HEX NUT, STAINLESS STEEL
0018	207510	1	RED KNOB
0019	209432	1	PIN LOCATOR SCREW (HEATING WELL)
0020	207632	4	HEX NUT, REGULAR, STAINLESS STEEL
0021	207766	4	8-32 X 1/2 RHMS STAINLESS STEEL
0022	207842	4	6-32 X 1/4 THMS STAINLESS STEEL
0023	203391	2	4-40 X 1/2 RHMS STAINLESS STEEL
0024	205772	2.5	WIRE 18 AWG HIGH TEMP, 600V, 450°F
0025	205736	4	HEATER ROD
0027	205779	4	RUBBER FEET
0028	204325	1	FISH PAPER 0.02 THICK 26 in. X 42 in. SHEET
0029	207634	1	NUT 4-40 HEX REGULAR STAINLESS STEEL
0031	101476559	3	TERMINAL
0040	205777	1	KNOB, ROUND BLACK w/BRASS BUSHING

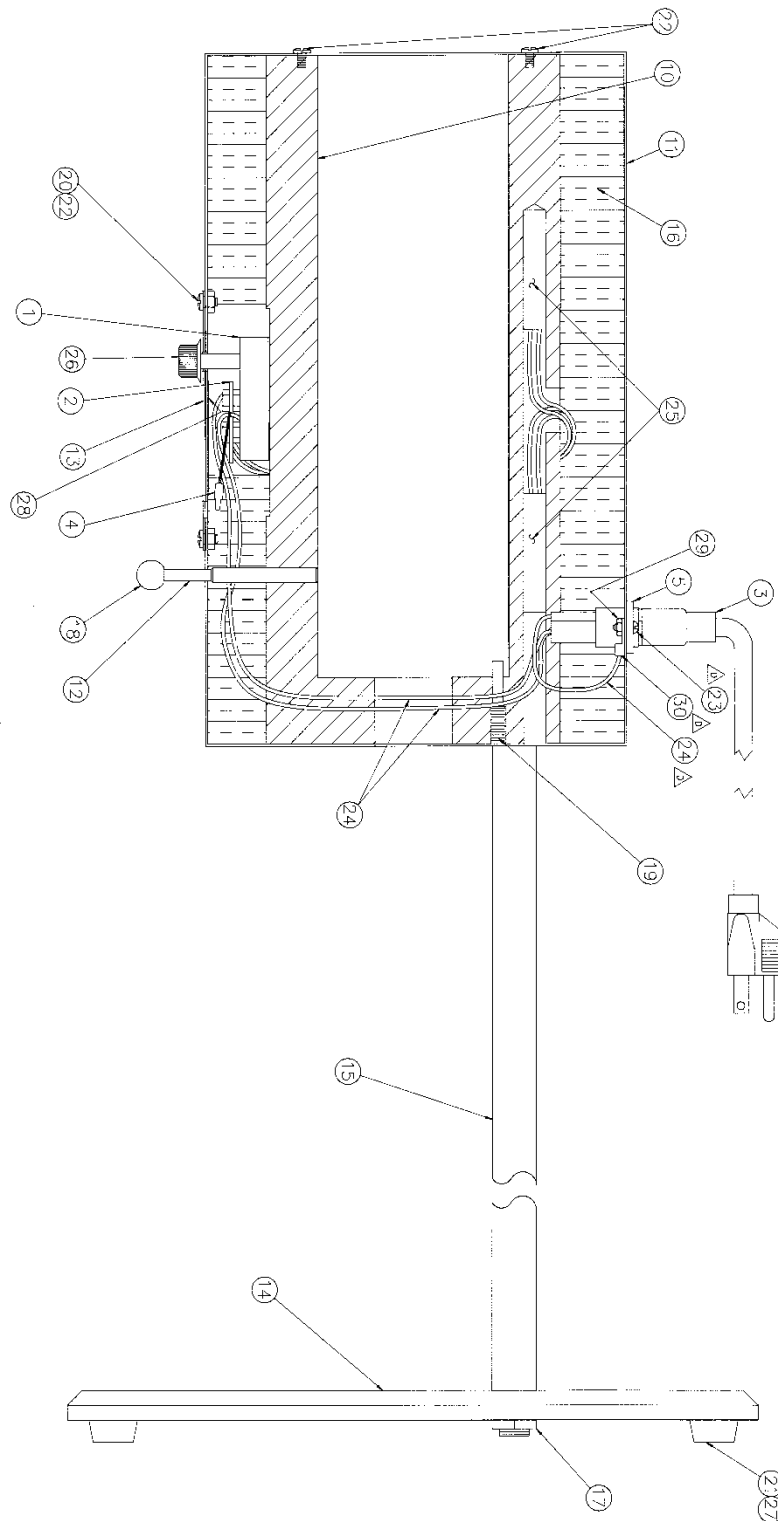

Figure 9-4 Heating Jacket, 115V

Table 9-5 Heating Jacket, P/N 101443622, 230 V

Item No.	Part No.	Quantity	Description
0001	205801	1	THERMOSTAT 50-600°F
0002	209491	1	THERMOSTAT MOUNT PLATE
0003	208452	1	CABLE POWER 115V 18 AWG
0004	209488	1	NEON LAMP & CUP-HEATER
0005	208438	1	PLUG INTL ELECT CODE TYPE
0006	203392	3	6-32 X 1/4 RHMS STAINLESS STEEL
0007	208658	2	WASHER FLAT 6 STAINLESS STEEL
0008	204290	6	FIBERGLASS SLEEVING
0009	204293	10	RING TERMINAL NO. 6 SCREW 16-14AWG
0010	209438	1	HEATING WELL
0011	209446	1	HEATING JACKET COVER
0012	209447	1	CELL SUPPORT
0013	204565	1	TEMPERATURE CONTROL TAG
0014	209553	1	BASE
0015	209554	2	LEG
0016	210459	24	BULK INSULATION
0017	206593	2	HEX NUT, STAINLESS STEEL
0018	207510	1	RED KNOB
0019	209432	1	PIN LOCATOR SCREW (HEATING WELL)
0020	207632	4	HEX NUT, REGULAR, STAINLESS STEEL
0021	207766	4	8-32 X 1/2 RHMS STAINLESS STEEL
0022	207842	4	6-32 X 1/4 THMS STAINLESS STEEL
0023	203391	2	4-40 X 1/2 RHMS STAINLESS STEEL
0024	205772	2.5	WIRE 18 AWG HIGH TEMP, 600V, 450°F
0025	205736	4	HEATER ROD
0026	205777	1	KNOB, ROUND BLACK w/BRASS BUSHING
0027	205779	4	RUBBER FEET
0028	204325	1	FISH PAPER 0.02 THICK 26 in. X 42 in. SHEET
0029	207634	1	NUT 4-40 HEX REGULAR STAINLESS STEEL
0030	101476559	3	TERMINAL
0103	209523	1	CAPACITOR, 10,000PF, 1000V, CERAMIC DISK
0104	204297	2	BUTT SPLICE
0105	205706	1	RESISTOR 5 OHM

Table 9-6 Backpressure Receiver Assembly, P/N 209445, Rev C

Item No.	Part No.	Quantity	Description
0001	208759	1	NEEDLE VALVE 1/8 X 1/8
0002	209441	1	BACKPRESSURE NIPPLE 1/8 NPT
0003	209448	1	RECEIVER BODY W/CAP 100ml
0004	204100	1	ADAPTER ELL 3/16 BARB X 1/8 FNPT
0005	204648	1	SAFETY LOCKING PIN
0007	205649	1	O-RING 0.176 ID X 0.070 W
0008	205668	1	O-RING 1-3/8 X 1/16

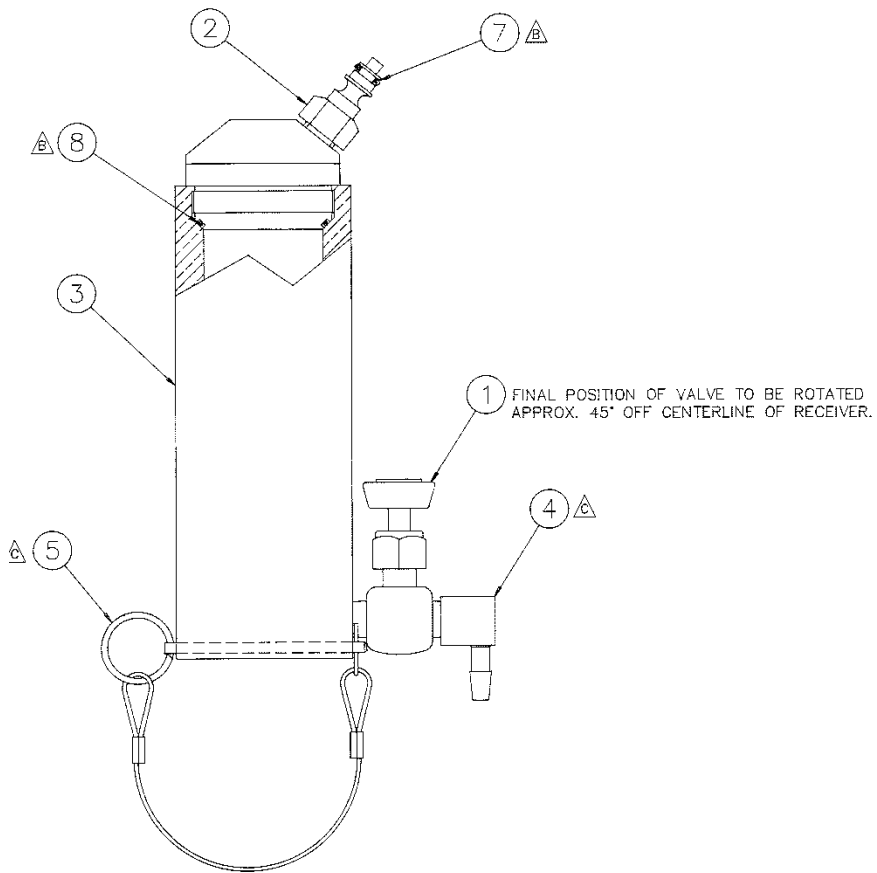

Figure 9-5 Backpressure Receiver Assembly

Table 9-7 Carbon Dioxide Pressuring Unit, P/N 209471, Rev E

Item No.	Part No.	Quantity	Description
0001	208612	1	CARTRIDGE BARREL
0002	208614	1	CARTRIDGE ADAPTER HEAD
0003	208759	1	NEEDLE VALVE, 1/8 X 1/8
0004	209470	1	REGULATOR, 1500 PSI
0005	209515	1	MANIFOLD BLOCK
0006	204648	1	SAFETY LOCKING PIN

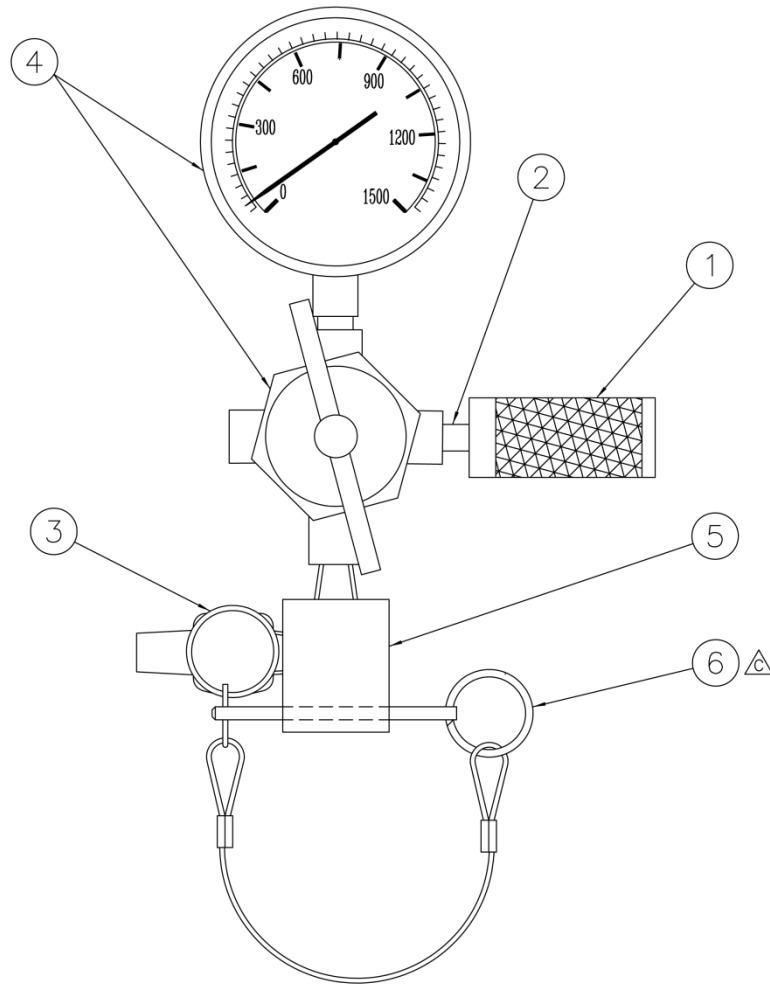

Figure 9-6 CO₂ Pressuring Unit

Table 9-8 PPA Pump Assembly, P/N 206869, Rev C

Item No.	Part No.	Quantity	Description
0001	207805	2	HYDRAULIC FLUID 1 QUART
0002	204092	1	TEE STREET 1/4NPT
0003	205406	1	HOSE 5750 PSI 5 LONG 1/8in. MNPT ENDS
0004	204093	1	QUICK DISCONNECT PLUG 1/8 FNPT 316 SS 5000 PSI
0005	204150	1	GAUGE 5000 PSI 3.5in DIAL 1/4 BOTTOM CON
0006	204899	1	REGULATOR 800-10K PSI HYD 3/8
0007	204096	1	ELBOW STREET 1/4FNPT X 1/4MNPT
0008	204086	1	ELBOW MALE 1/4T X 3/8 MNPT BRASS
0009	204095	1	BUSHING REDUCING 1/4 MPPT X 1/8 FNPT
0010	208977	7	TUBING 1/4 OD X 0.035 WALL 304S
0011	204097	1	BUSHING REDUCING 3/8 MNPT X 1/4 FNPT
0012	204098	1	NIPPLE 3/8 NPT 10K PSI
0013	205222	1	HYDRAULIC HAND PUMP HP 10K PSIG 2
0014	206893	1	MEASURING CUP 500ml, STAINLESS STEEL

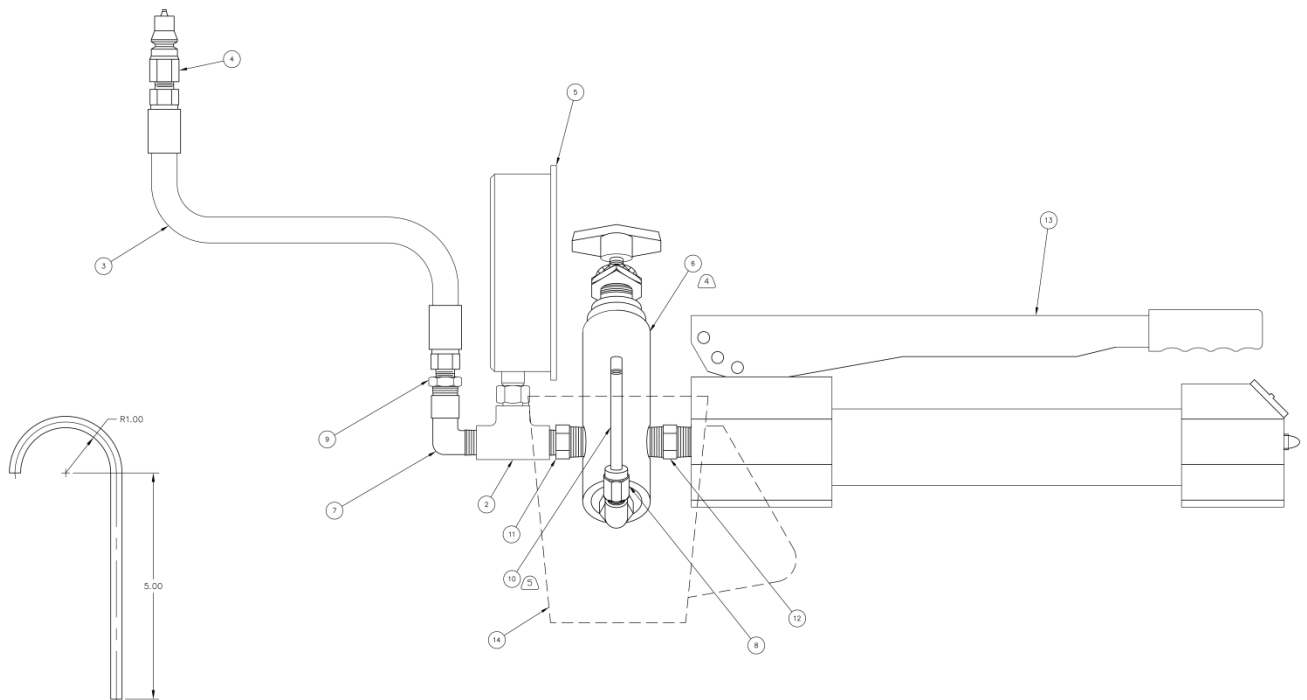

Figure 9-7 PPA Pump Assembly

Table 9-9 Hydraulic Pump, P/N 205222

Item No.	Part No.	Quantity	Description
0001	12223	3	BALL, 3/16 DIA
0002	10519	3	SET SCREW
0003	251893	3	PIN
0004	251925	6	RETAINING RING (EXTERNAL)
0005	*251923	1	U-CUP
0006	*305977	1	WARNING DECAL
0007	351129	1	TWO-SPEED PISTON
0008	64886OR9	1	HANDLE
0009	11127	1	PRESSURE PLUG, 3/8 NPTF
0010	*251965	2	O-RING, 2-7/16 X 2-1/4 X 3/32
0011	*250611	1	BACKUP WASHER, 1/2 X 3/8 X 0.049 (ASSEMBLE WITH CONCAVE SURFACE TOWARDS O-RING.)
0012	*15279	2	O-RING, 1/2 X 3/8 X 1/16
0013	*12557	1	O-RING, 11/32 X 7/32 X 1/16
0014	*215075	1	FILTER
0015	21278	1	RELIEF VALVE ASSEMBLY
0016	48011	1	RELIEF VALVE ASSEMBLY (325 PSI)
0017	351148	1	TRADE NAME DECAL
0018	351120	1	RESERVOIR TUBE
0019	251889	1	TIE ROD
0020	58681	1	RESERVOIR CAP
0021	251903	1	CAP NUT (TORQUE TO 90/110 IN. LBS. FULLY ENGAGE ACORN NUT ONTO TIE ROD BEFORE TORQUING TO BODY.)
0022	351245	1	FILLER CAP
0023	*10274	1	O-RING, 7/8 X 11/16 X 3/32
0024	11390	1	FLEX GRIP HANDLE
0025	253234	1	DECAL (OIL PIVOT PINS)



An asterisk identifies parts in the repair kit, P/N 205223.

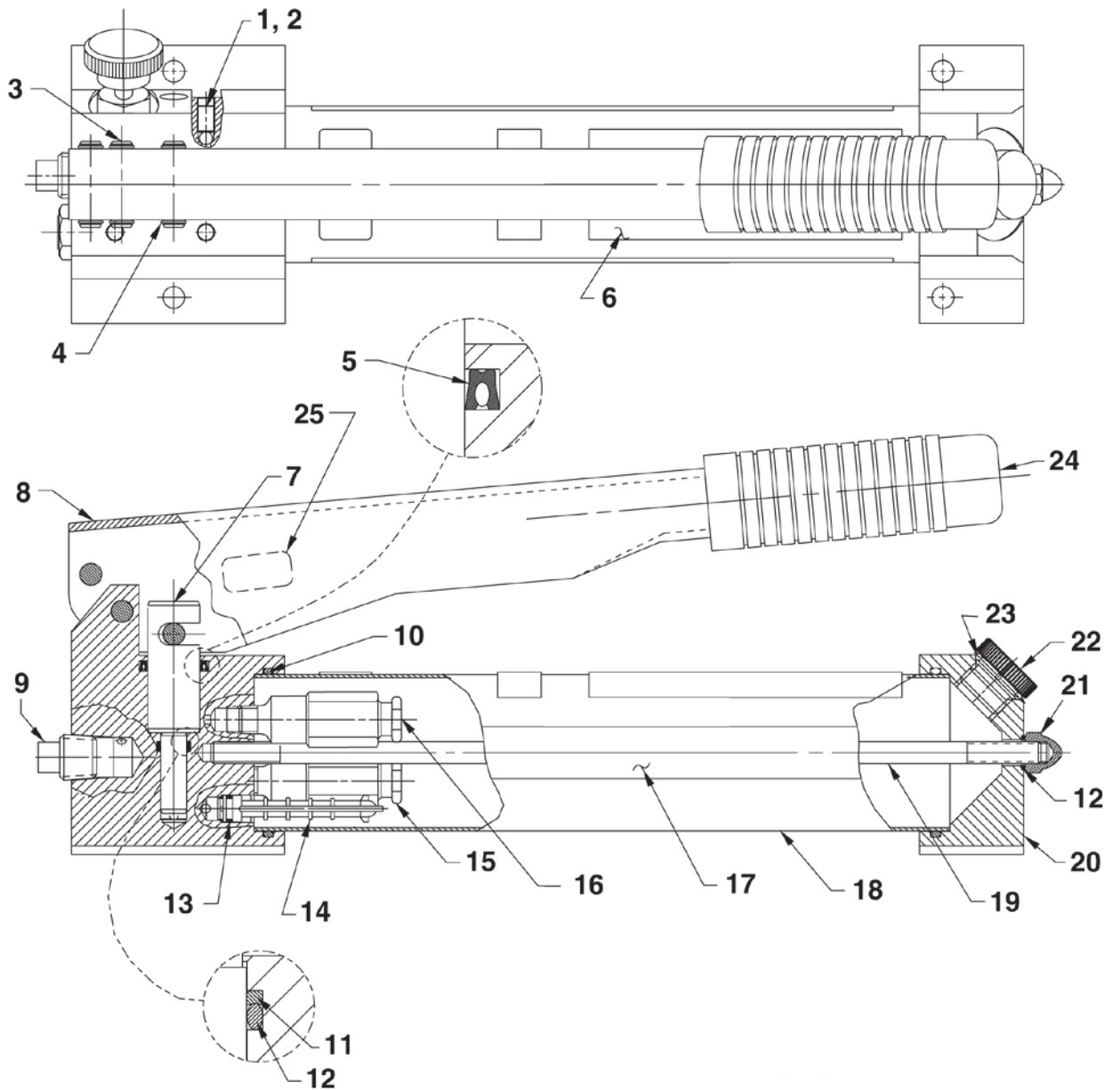

SOURCE: SPX Power Team[®]

Figure 9-8 Hydraulic Pump, Top & Side Views

Table 9-10 Hydraulic Pump, End View, P/N 205222

Item No.	Part No.	Quantity	Description
0001	215301	1	PRESSURE DECAL
	252247	1	PRESSURE DECAL (GERMAN; FOR P19-PFAFF ONLY)
0002	*215907	2	DECAL
0003	64863	1	PUMP BODY
0004	*10265	1	O-RING, 5/16 X 3/16 X 1/16
0005	*10300	1	O-RING, 5/8 X 15/32 X 5/64
0006	34871	1	GUIDE
0007	29783	1	STEM
0008	29827	1	KNOB
0009	12223	2	BALL, 3/16 DIA.
0010	10519	2	SET SCREW (1/4-20 UNC X 3/8 LG.; TORQUE TO 75/80 IN. LBS.)
0011	351952	2	VALVE SCREW (TORQUE TO 480/500 IN. LBS.)
0012	*14874	2	SOFT COPPER WASHER, 0.700 X 1/2 X 1/32
0013	*10444	4	COMPRESSION SPRING, 3/16 I.D. X 13/32 LG.
0014	*10378	2	STEEL BALL, 3/8 DIA.
0015	*211797	2	COMPRESSION SPRING, 5/32 O.D. X 5/8 LG.
0016	15130	2	PLUG 1/16 NPTF
0017	*10375	2	STEEL BALL, 1/4 DIA.



An asterisk identifies parts in the repair kit, P/N 205223.

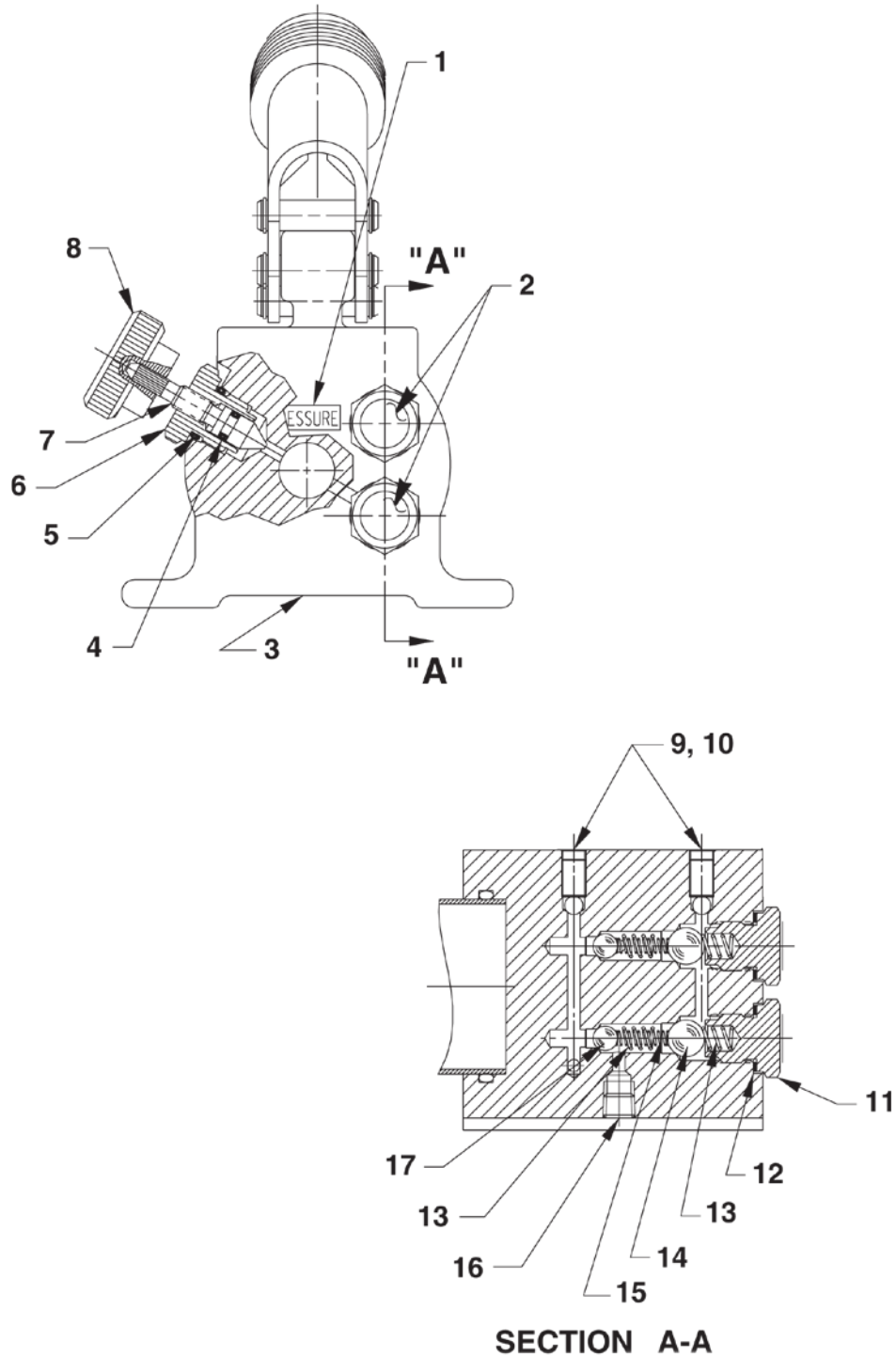

SOURCE: SPX Power Team[®]

Figure 9-9 Hydraulic Pump, End View

Table 9-11 Pressure Regulator, P/N 204899

Item No.	Part No.	Quantity	Description
0001	215683	1	REGULATOR LOCKING NUT
0002	215428	2	SPRING RETAINER
0003	309079	1	POPPET
0004	215430	2	BACKUP WASHER (3/8 X 9/32 X 3/64)
0005	10266	1	O-RING (3/8 X 1/4 X 1/16)
0006	309078	1	SEAT FITTING
0007	215693	1	TEE KNOB
0008	215721	1	STEM
0009	10396	1	JAM NUT (3/4-16)
0010	309077	1	SPRING HOUSING
0011	215429	1	COMPRESSION SPRING (1.100 O.D. X 2-1/2 LG.)
0012	47648	1	REGULATOR BODY
0013	215431	1	COMPRESSION SPRING
0014	13755	1	O-RING (9/16 X 13/32 X 5/64)

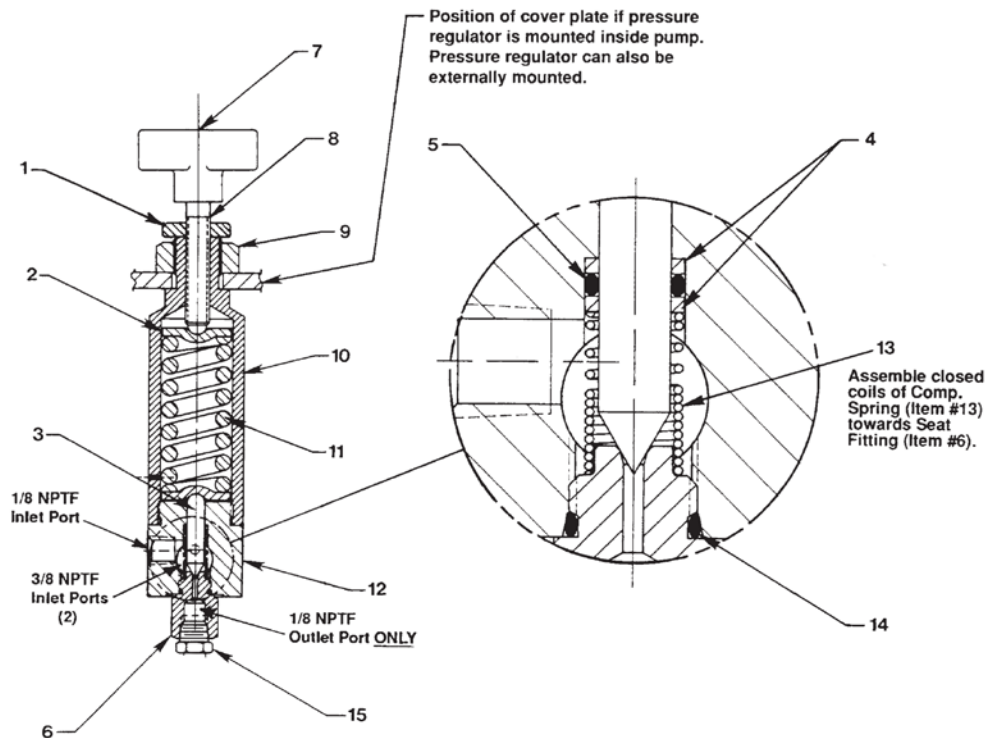

SOURCE: SPX Power Team[®]

Figure 9-10 Pressure Regulator

10 Warranty and Returns

10.1 Warranty

Fann Instrument Company warrants its products to be free from defects in material and workmanship for a period of 12 months from the time of shipment. If repair or adjustment is necessary, and has not been the result of abuse or misuse within the twelve-month period, please return, freight prepaid, and correction of the defect will be made without charge.

Out of warranty products will be repaired for a nominal charge.

Please refer to the accompanying warranty statement enclosed with the product.

10.2 Returns

For your protection, items being returned must be carefully packed to prevent damage in shipment and insured against possible damage or loss. Fann will not be responsible for damage resulting from careless or insufficient packing.

Before returning items for any reason, authorization must be obtained from Fann Instrument Company. When applying for authorization, please include information regarding the reason the items are to be returned.

Our correspondence address is:

Fann Instrument Company

P.O. Box 4350

Houston, Texas USA 77210

Telephone: 281-871-4482

Toll Free: 800-347-0450

FAX: 281-871-4446

Email fannmail@fann.com

Our shipping address is:

Fann Instrument Company

14851 Milner Road, Gate 5

Houston, Texas USA 77032